

# Environmental protection with Swirl droplet separator (DTA)



**Körting**

HANNOVER AG

THE  
**EJECTOR**  
COMPANY

# Swirl droplet separator (DTA)

**Droplet separators** play a key role in complying with emission regulations. As components in gas scrubbers (which are used to clean waste gas flows) they therefore help protect the environment.

Waste gas entering swirl droplet separators is cleaned by separating out the droplets. At this **phase-separation stage** the gas flow is rotated and propelled towards the edge of the separator via a **swirl generator**. Three-dimensional vanes prevent inlet losses and turbulent flow occurring. Stable and consistent rotational flow forms in the adjacent helically coiled tube. Due to the centrifugal force, the droplets are thrust to the wall of the tube and collected there.

The **separation chambers** in Körting swirl droplet separators are designed as **helically coiled tubes**. This special design prevents the liquid film that forms on the tube wall from being conveyed to the gas outlet. The drag force of the gas has no impact on the separated droplets' flow.

The liquid doesn't flow in the direction the gas rotates in, but downwards. This effect is achieved by the special profiles and layout of the helically coiled tubes that lead downwards towards the direction the gas rotates in. The liquid is collected and removed near the swirl generator.

The design also makes **cleaning** the inside of the helically coiled tube **during operation** easier. In complex applications special additional rinsing systems effectively help to prevent deposits on the separator and on the swirl generator's vanes. This type is frequently required for challenging products where adhesion is a problem. **Rinsing systems** can be used while the machinery is in operation without generating new droplets in the cleaned gas.

The swirl droplet separators are big enough so that large quantities of liquid, such as film forming on the walls and **splashes**, can be drained off too.

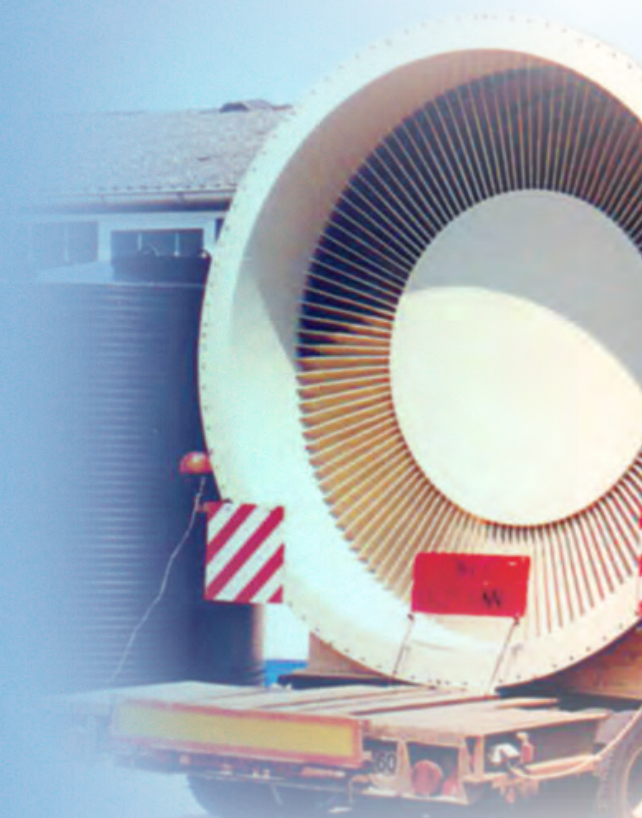
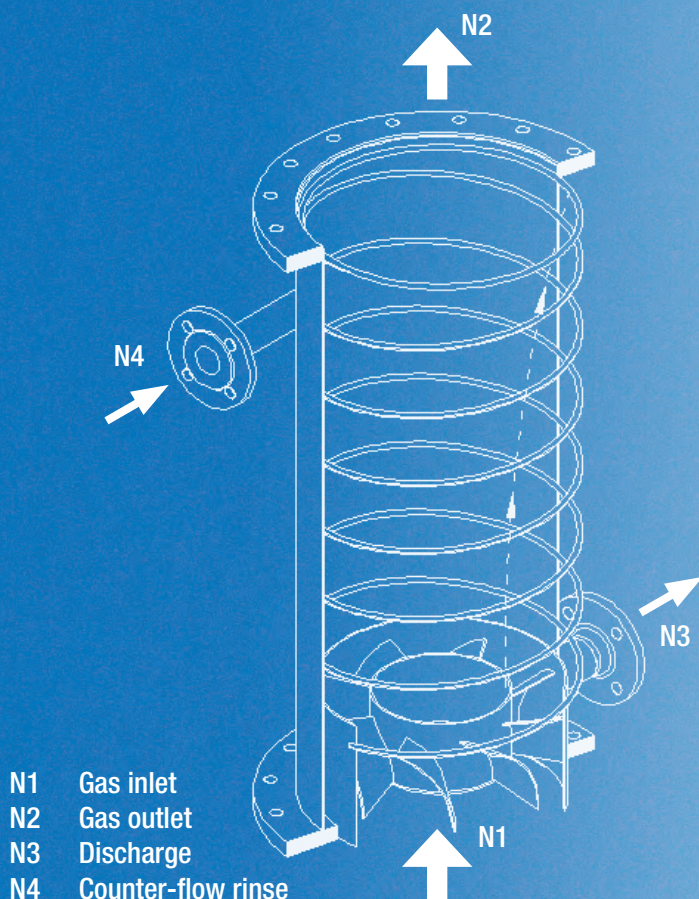

## Applications

Körting swirl droplet separators are ideal for use as follows:

- in gas scrubbers and vacuum plants
- to remove condensate in chimneys
- in evaporation plants to ensure the vapour condensate is excellent quality
- to remove complex products (e.g. that tend to polymerise)

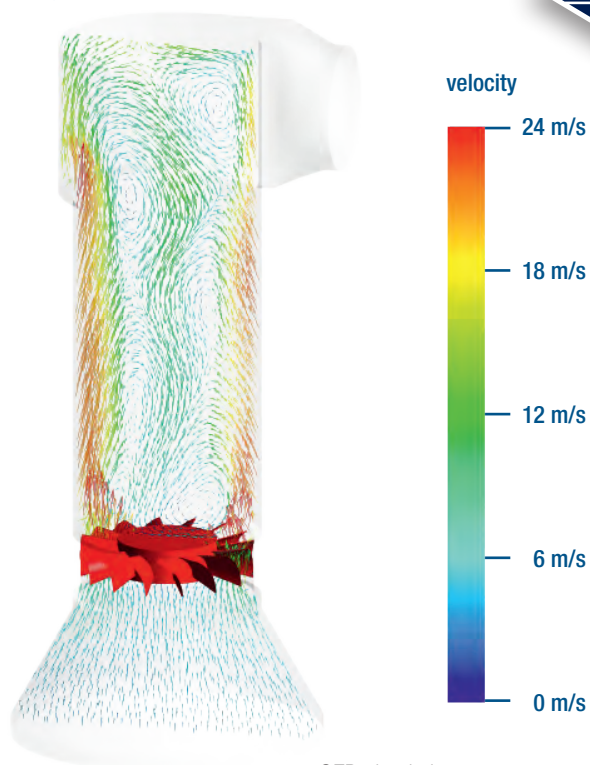

CFD simulation

## Sizes

- standard sizes in DN 200 to DN 3000 nominal widths
- further sizes on request

## Materials

- carbon steel, stainless steel
- coated steel (rubber, Halar etc.)
- plastics: GFK, PP, PVC, PVDF reinforced and non-reinforced
- special materials



DTA chimney DN 3 000 for 290 000 m<sup>3</sup>/h

## Transparent trial separator in operation

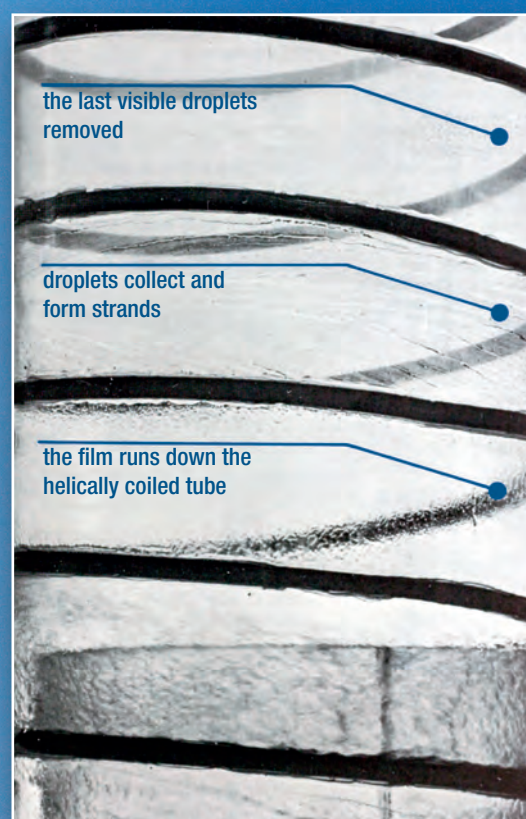

# Design example

## Design example

A volume flow of 1 000 m<sup>3</sup>/h is analysed. A nominal size of DN 300 is selected.

The flow rate is shown in the diagram at the top. It totals  $c = 4$  m/s.

The pressure loss is shown in the diagram in the middle:  $\Delta p = 2$  mbar.  
The best range to work with is generally between 3 mbar and 5 mbar.

The bottom diagram shows the critical limit drop. This is 10.5  $\mu\text{m}$  in the example selected.

All droplets with a diameter greater than this threshold are removed. However, only a smaller percentage (the degree of fractional efficiency) of smaller droplets are drained off.

## Special characteristics

- excellent separation (up to 5  $\mu\text{m}$ )
- little pressure loss
- rinsing during operation
- little maintenance required
- high levels of reliability and availability

## Characteristic curves

DN 200 to DN 600

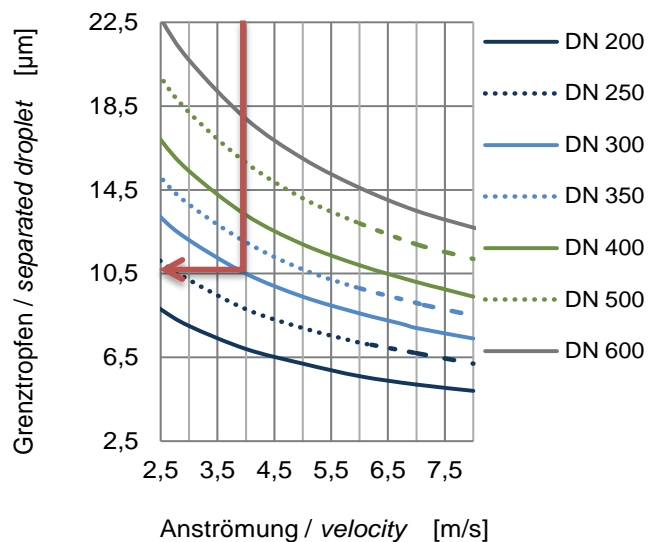
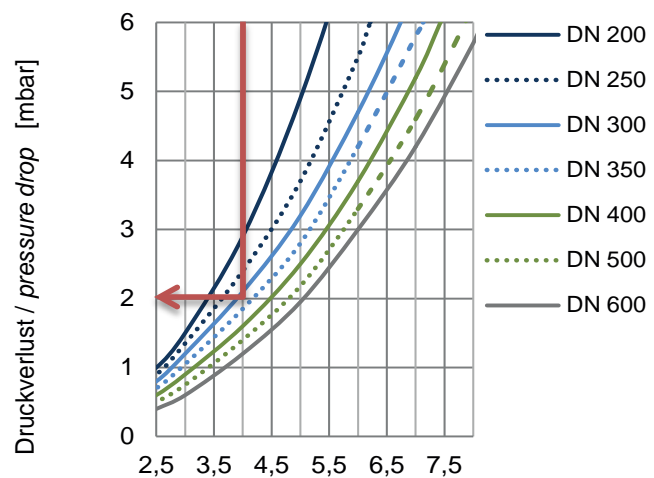
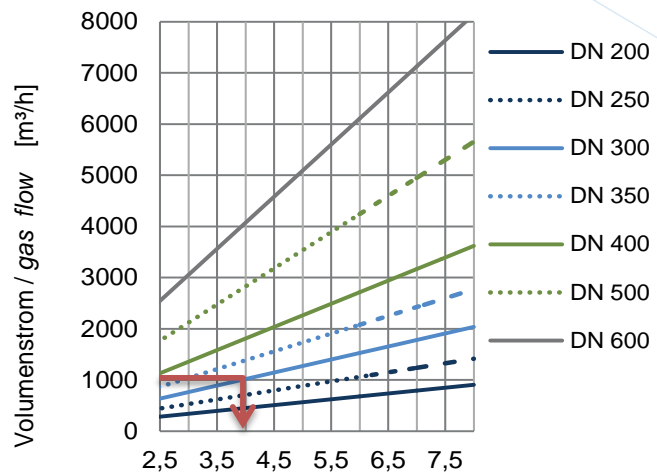

For custom-made designs please request our Körting swirl droplet separator questionnaire!

DN 700 to DN 1 400

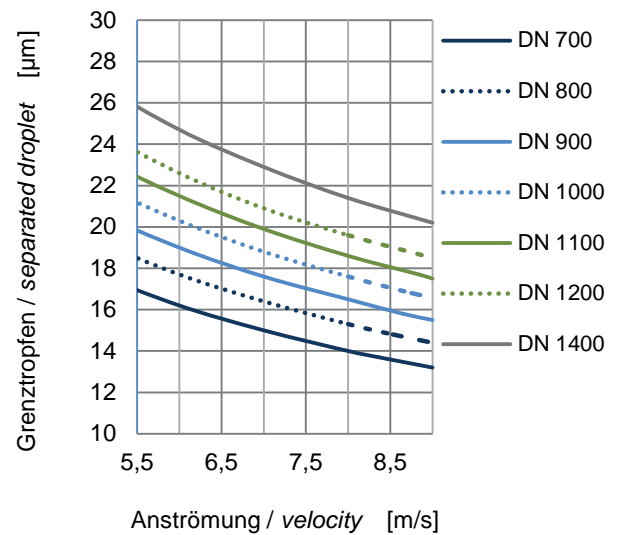
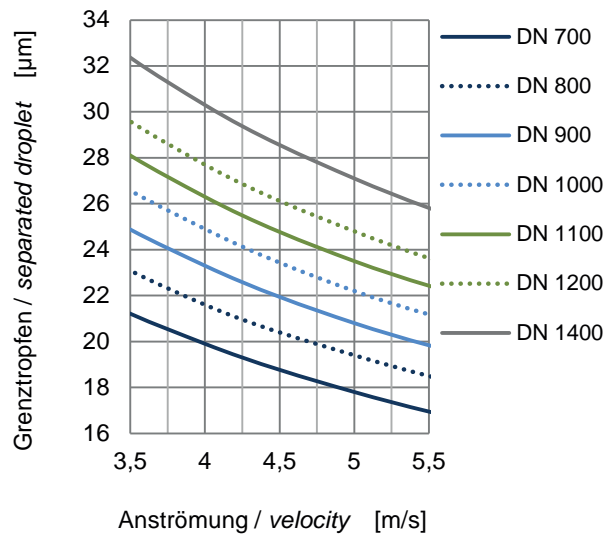
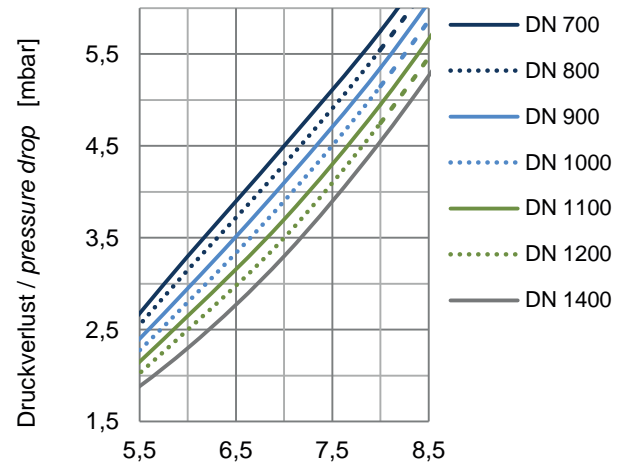
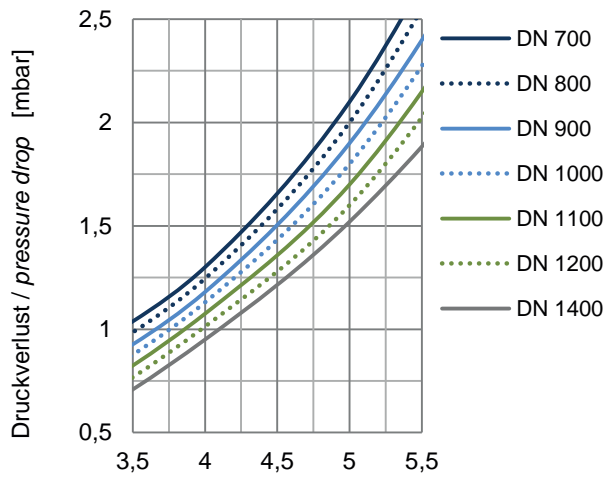
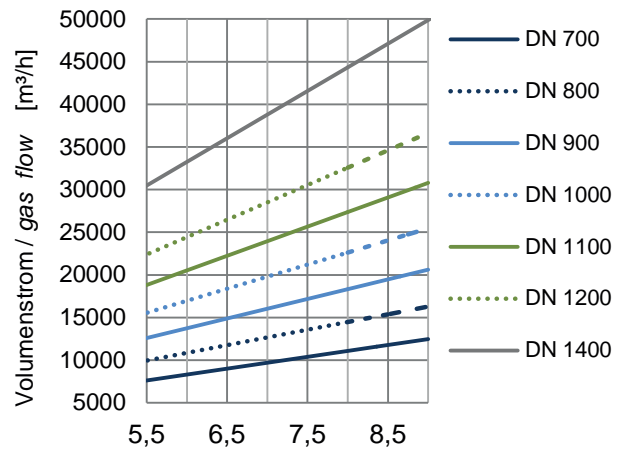
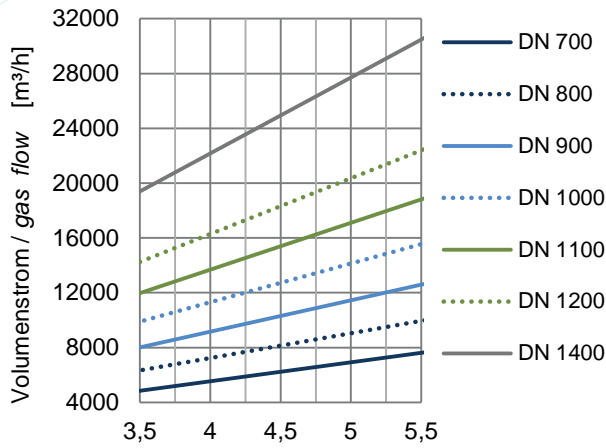

# Design example

## Characteristic curves

DN 1 600 to DN 3 000

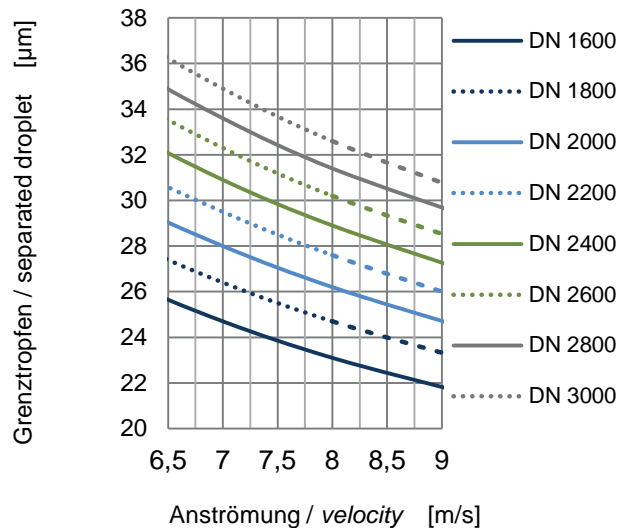
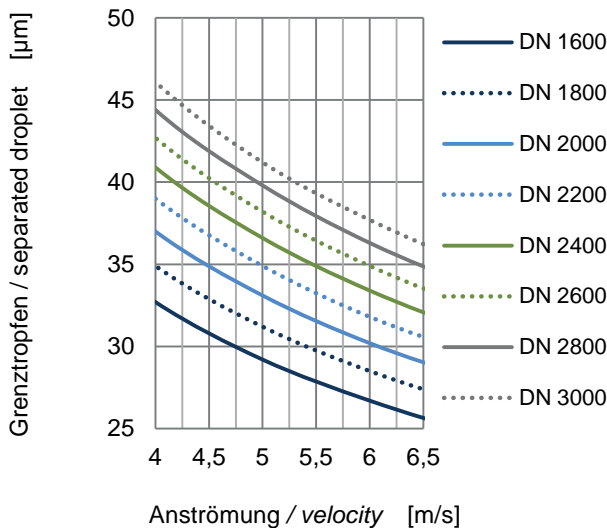
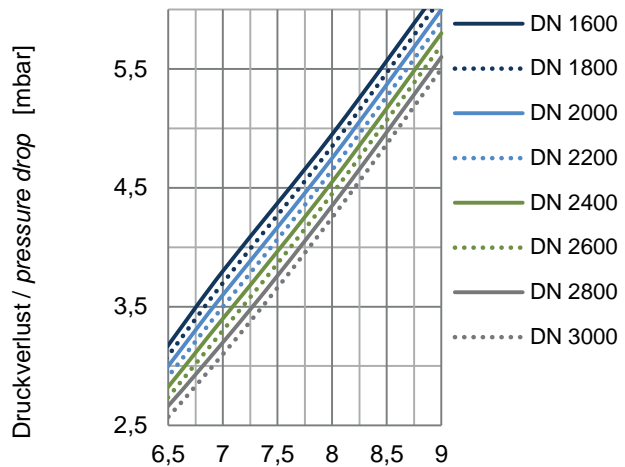
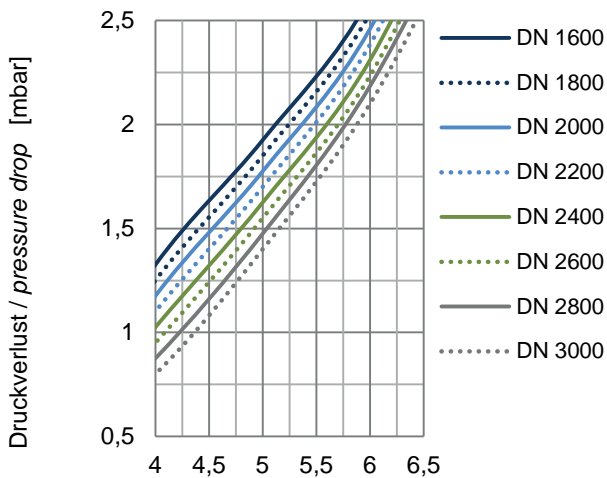
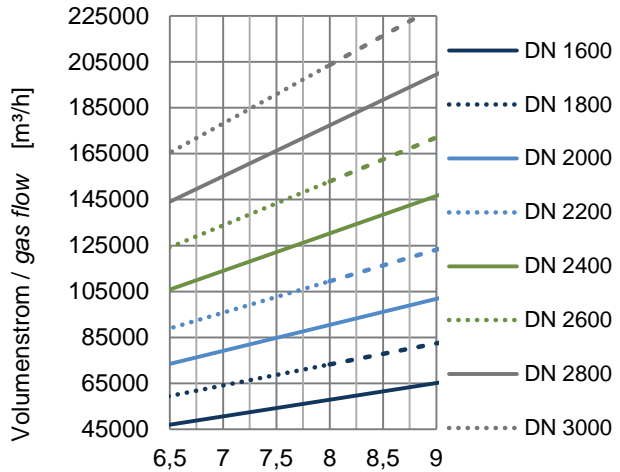
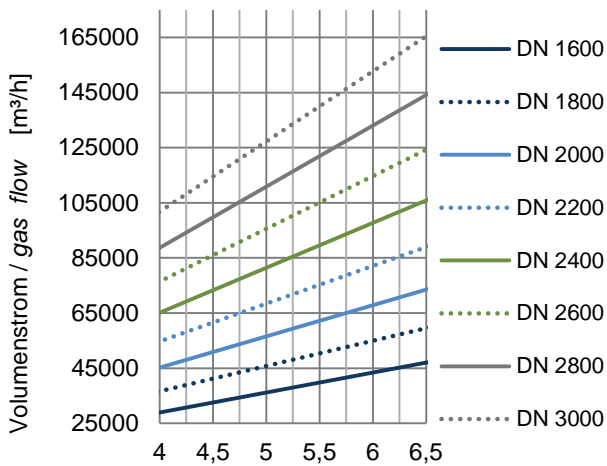



PVDF swirl generator in the workshop



Chimney swirl droplet separator at BASF



Chimney swirl droplet separator at Bayer



Swirl droplet separator made of PVDF/GFK in production

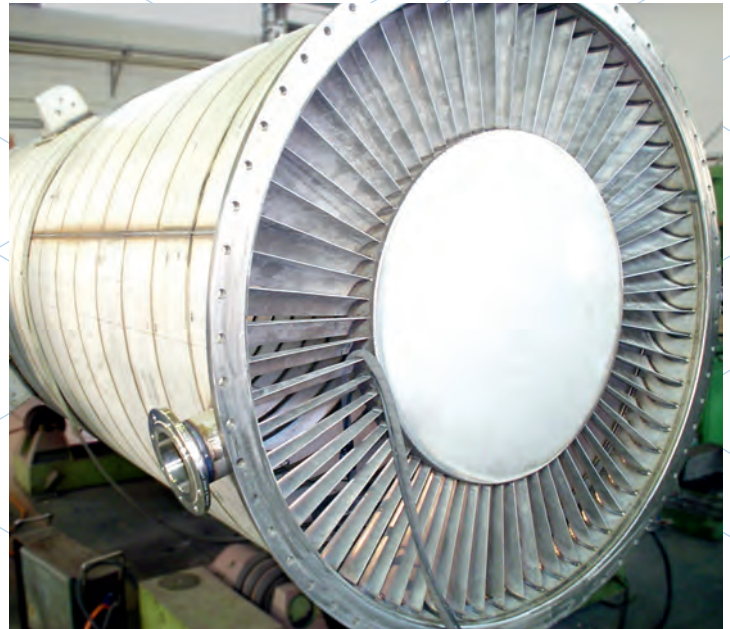

Swirl droplet separator made of stainless steel in production



Swirl generator tube in a tube in the workshop



DTA 200 with Halar coating

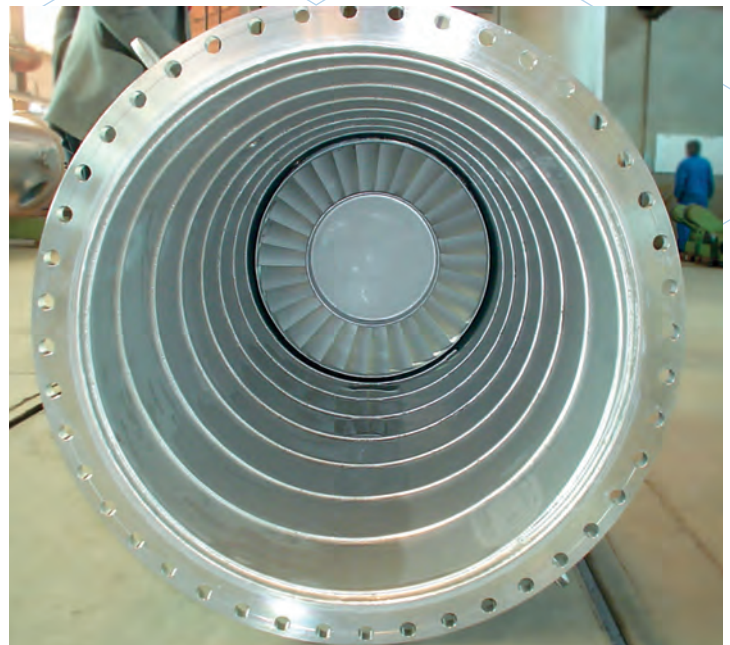

The inside of a helically coiled tube



FED s.r.l.

Via dei Valtorta, 2  
20127 MILANO  
Italy

Tel.: +39 02 26826332

Fax: +39 02 26140150

E-mail: [fed@fed.it](mailto:fed@fed.it)

[www.fed.it](http://www.fed.it)