

## Burner control unit FDA 602x



EN 298 / EN 230 2012

isolating enclosures with  
screwed connection

2-channel microprocessor  
controlled program

air valve control for  
heating / cooling prevention

continuous operation with  
ionisation

intermittent operation with UV cell

continuous operation UV with  
PWA 6023/6024 and fail-safe UV-  
flame detector (ex. FD 3025)

suitable for impulse-firing-systems

**optional:**

rinsing of the burner and work  
with external allowed time and  
„air valve“ indicator,  
HEATING / COOLING mode.

The burner control system FDA / PWA 602x is designed for operation at continuous operating heat treating units. The universal use and also the easy integration in the main system are specific for this control unit.

It also complies to the requirement of the newest European Standard EN 298 and EN 230.



# Burner control unit FDA 602x

## Description

The electronic control is fail-safe against external electrical influences and corresponds to the hardest industrial conditions. The reproducible program sequence precise by microprocessor technology works autonomously without auxiliary and utility systems. The control inputs are non-reactively connectable. The failure message contacts can be included into external signal circuits. The operating voltage of the fuel valves can deviate from the auxiliary voltage of the controller. The following

additional functions are because of our customer's requests:

- Burner pre-ventilation with external timing and a additional LED display „Air valve“.
- Heating / cooling- pre-selection of operation mode by Split-Range-Controller.
- Ignition repeat with max. 3 program cycles accord. to EN 746-2.

## Spezification

	FDA 6021	PWA 6023	FDA 6024	FDA 6028	FDA 6029
<b>flame detector</b>					
continuous internal	ionisation	-	ionisation	ionisation	ionisation
continuous external	-	UV*	-	-	-
intermeitted internal	UV	-	UV	UV	UV
fuel valves	2	2	2	2	2
<b>optional</b>					
air valve	-	-	1	-	1
mode	-	-	rinse	ignition repeat	cooling / heating

\* external flame detector, e.g. FD 3025, for continuous operation.

## Program run for FDA 6021 - PWA 6023

FDA 6021 / PWA 6023 - 2-stange standard version.

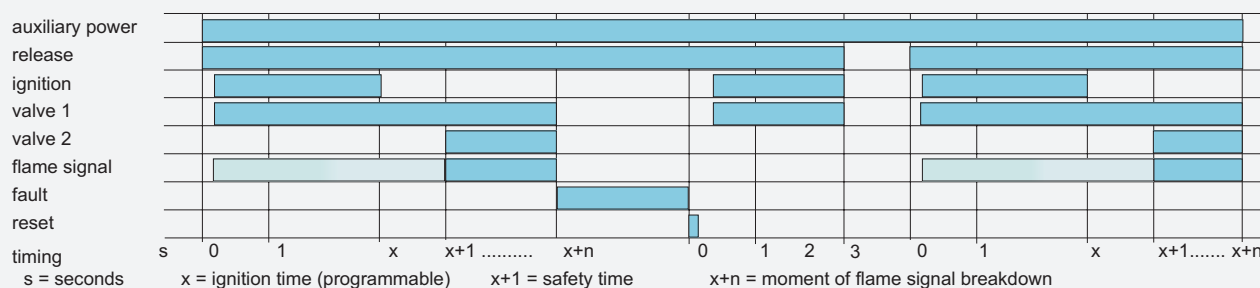

DATASHEET

# Burner control unit FDA 602x

FDA 6021 with integrated flame monitor for continuous operation by ionisation monitoring with sensor electrode and intermittent by UV monitoring with UV cell, such as P607 or R1848.

PWA 6023 with external flame monitor such as FD 3025, for continuous duty.

## Program run for FDA 6024

FDA 6024 - 2 stage version with an additional output and input to piloting a air valve. The air valve is at any time insertable also outside of the program cycle.

It serves for not safety-related rinsing of the burner and works with external allowed time.

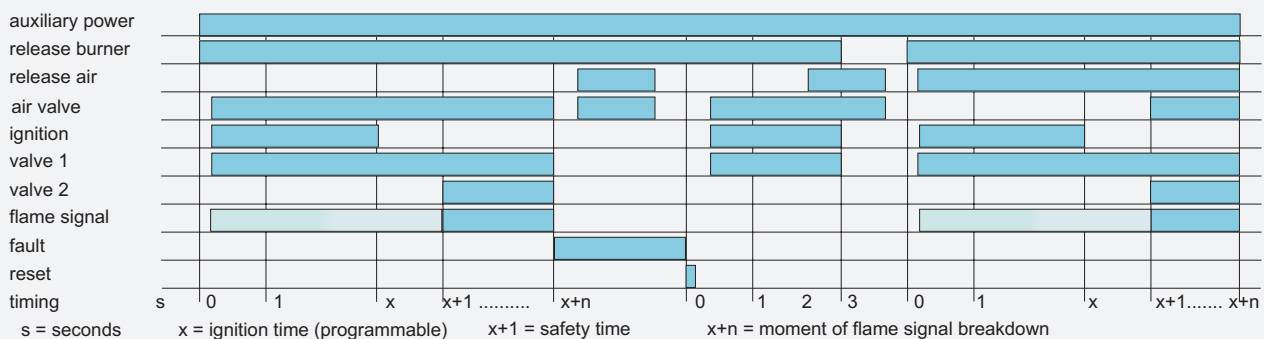

## Program run for FDA 6028

FDA 6028 – ignition repeat with max. 3 program cycles accord. to EN 746-2.  
10 sec. dead time between the program cycles.

- Optimised functionality by program analysis „rugged combustion“:  
If flame loss should be recognized during one of the two first program cycles, within 5 seconds at expiration of the safety time, the program goes to the ignition repeat routine.

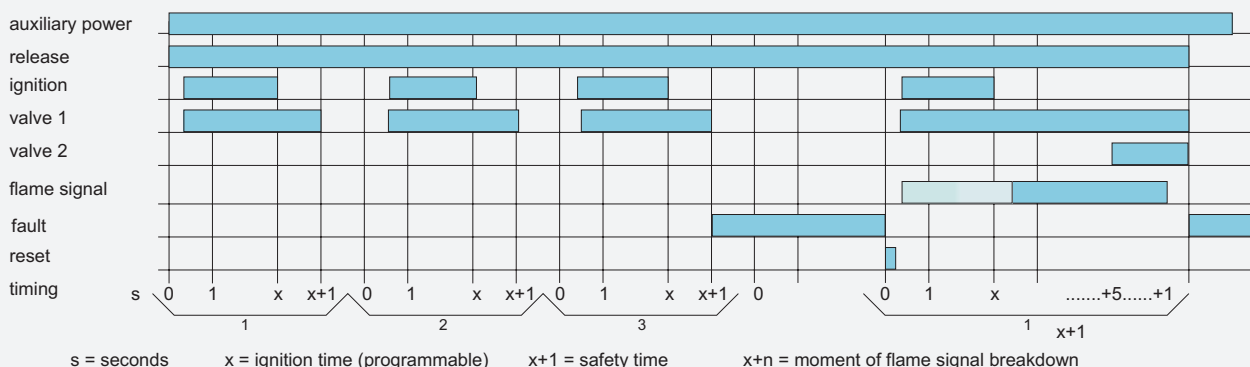

**After failure and reset again all re-ignitions are available.**

DATASHEET

# Burner control unit FDA 602x

## Program run for FDA 6029

FDA 6029 –2 stage version for operation at impulse firing with operation mode heating / cooling. Separate output for the air valve and preselection of operation mode.

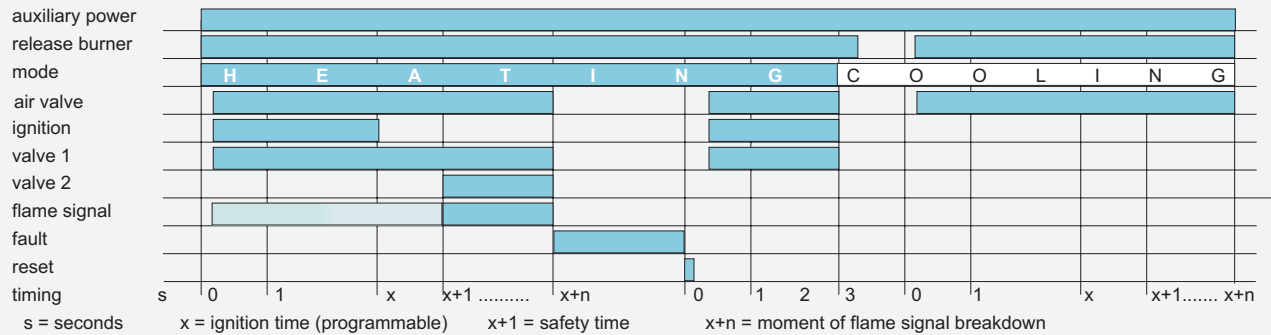

## Technical data

### operating voltage

115V or 230V, 50/60Hz; -10% / +15%

### current consumption

at 230V - appr. 26mA, at 115V - appr. 52mA

### loading

approx. 6,0VA

### power loss

max. 4,2W

### safety times

3 - 5 - 7 - 10 seconds for all constructions.

### flame detector

- continuous duty operation
- accord. to EN298 and N230.
- UV-operation intermittent.
- UV-continuous duty operation at PWA 6023 with external continuing licensed flame monitor by a separate input.

### FDA-flame signal

>1...2µA, metering points on the front panel,

metering without current circuit interruption, maximum 30µA.

### Attention: High voltage!

- ≥ 2µA - ON
- ≤ 1,5µA - OFF

### temperature range

0°C / +60°C

### program run

microprocessor controlled, no waiting time between two cycles.

### design

isolating enclosures with screwed connection, consisting of stand, hood and inner plate. Base: 75x158mm. Total heigh: 130mm

### weight

700g

### protection class

IP40

# Burner control unit FDA 602x

## Connection example 1/5 for FDA 6021 / 6028

Monitoring of ionisation with separate ignition- and monitoring electrode.

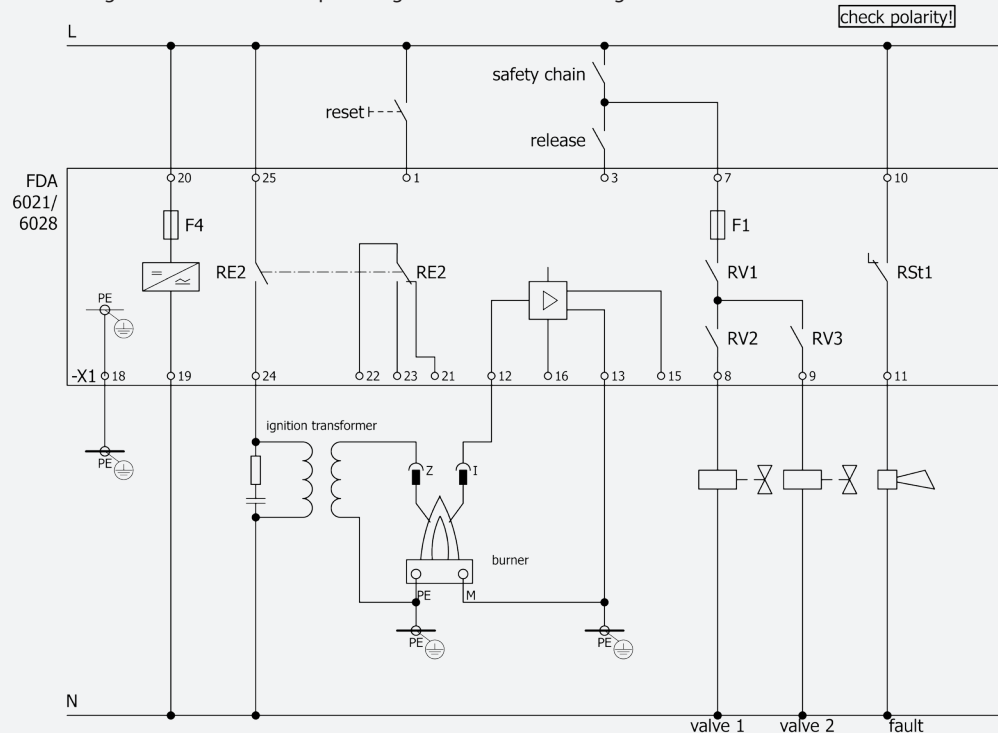

## Connection example 2/5 for PWA 6023

Monitoring of ionisation with external flame detector / signaling contact input.

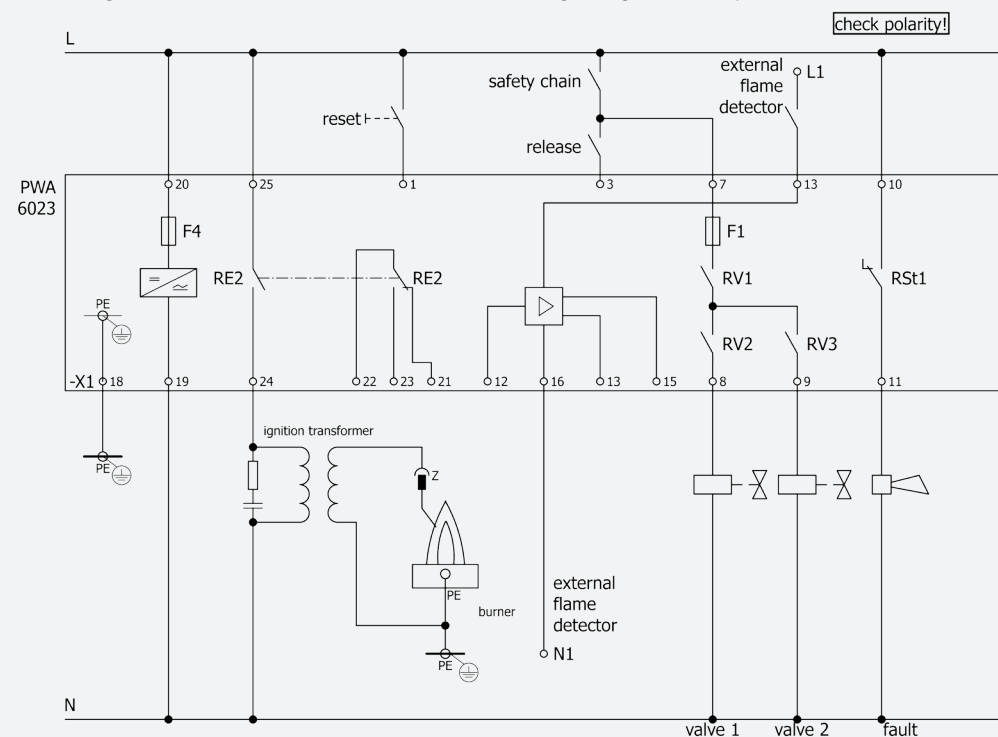

DATASHEET

# Burner control unit FDA 602x

## Connection example 3/5 for FDA 6024

Monitoring of ionisation with separate ignition- and monitoring electrode.

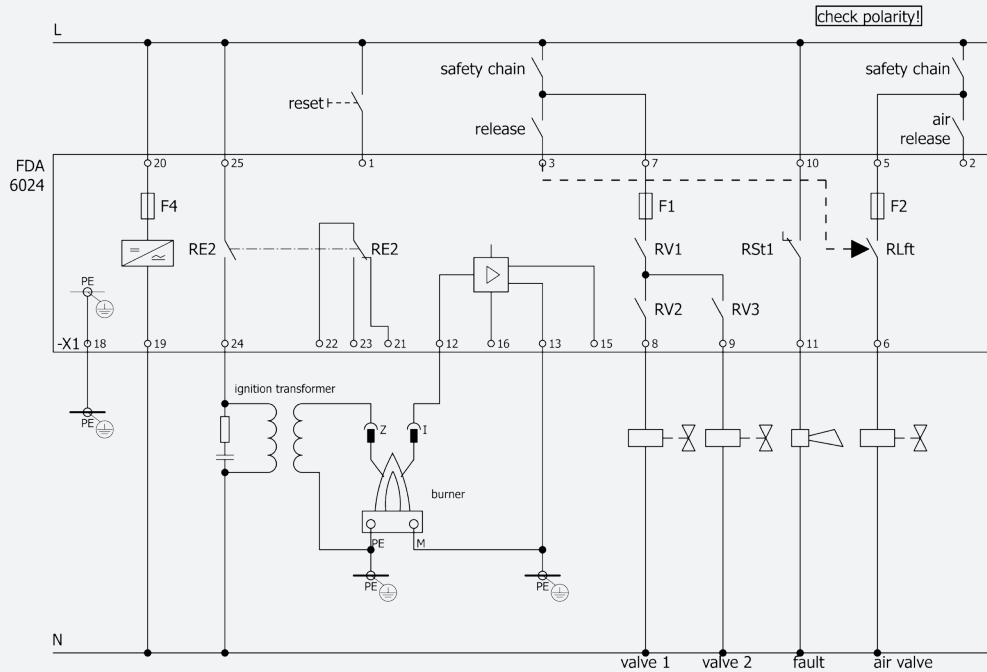

## Connection example 4/5 for FDA 6029

Monitoring of ionisation with separate ignition- and monitoring electrode.

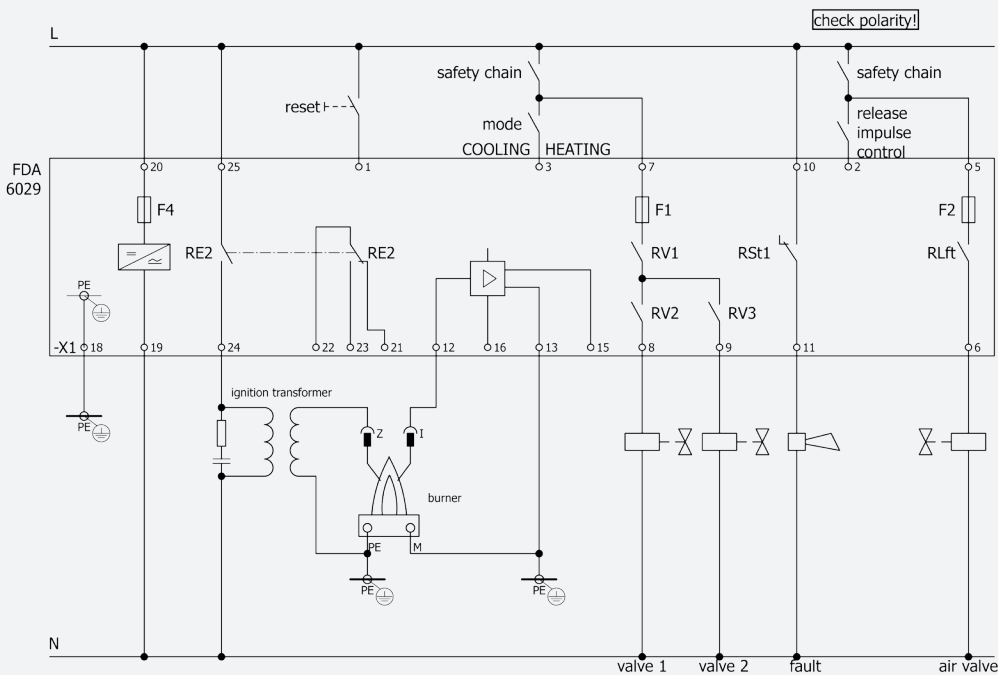

DATASHEET



# Burner control unit FDA 602x

## Types of monitoring for FDA 602x

Monitoring of ionisation with common / separate ignition- and monitoring electrode, monitoring with UV-tube.

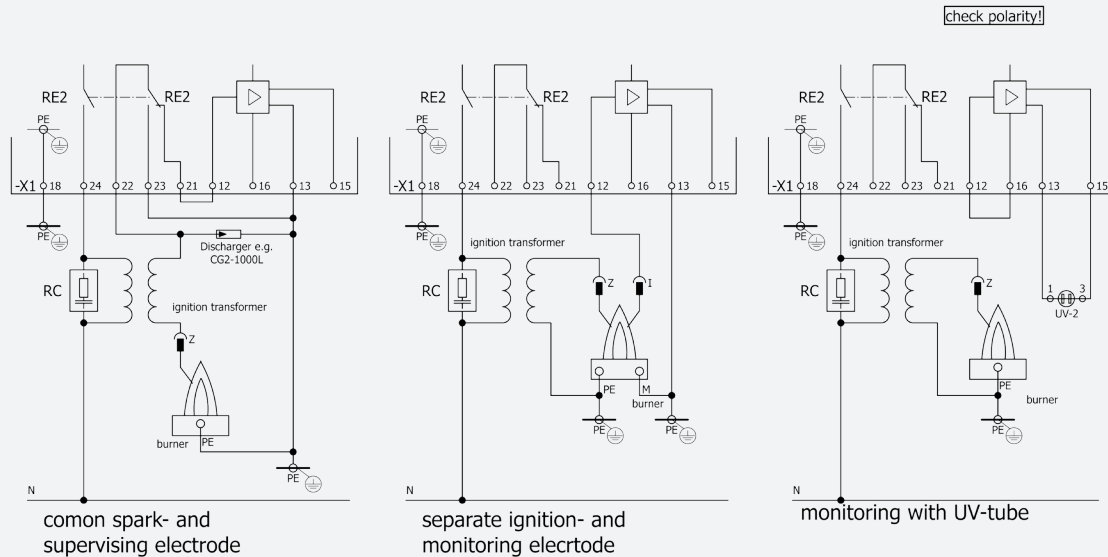

## Contact load

	ignition	valve 1 + 2	air valve	fault
<b>V AC</b>				
max. load	500VA	250VA	250VA	250VA
max. voltage	250V	250V	250V	250V
max. current	2A	1A	1A	1A
<b>V DC</b>				
max. load	---	24W	100W	100W
max. voltage	---	24V *	100V	100V
circuit breaker external	---	---	---	1A
circuit breaker internal	---	T1A	T1A	---

**\*Attention!**

do not use for low-voltage protection (VDE 0100 DIN 40803) VDE 0860/08.91

DATASHEET

# Burner control unit FDA 602x

## Urgent advise

The declared values valve 1 + 2 are the maximum sum of the individual valve datas,  $\cos.\Phi = 0,6$ , because relays F1 has to switch the total current.

## **The switching contacts should be in principle wired after mode of operation:**

- a. AC voltage: RC-combination or varistor (metallic oxide)
- b. DC voltage: free-wheeling diode ( $U_s > 5 \times U_v$ )

## Switching frequency:

at  $\cos.\Phi = 1,0$ :  $2,5 \times 10^5$

at  $\cos.\Phi = 0,6$ :  $2,5 \times 10^5$

## Maximum length of cable:

Ionisation monitoring max. 75m by separate cable laying of the Power cable by cable quality single wired ignition cable type SIHFZU min.  $1 \times 1\text{mm}^2$ .

UV-monitoring max. 50m by cable quality Ölflex type YSCY-J.

All other cables max. 500m by cable quality Ölflex.

**Special regulations of the plant operators are to be considered absolutely!**

**CE-No.: 0063 BT 1053**

*All rights reserved. Transfer, processing and reproduction of this publication or parts thereof, without the express permission of the company HANS HENNIG GmbH, is forbidden.*

*Technical modifications, which serve the progress, are reserved.*



# Burner control unit FDA 602x

## Appendix to burner control unit FDA 60xx

For a failure-free operation of the burner control unit FDA 60xx, you should pay attention on the early stage of development. Additional modifications on existing plants increase the costs. To prevent unnecessary expenses, please follow the remarks.

### General

The burner control unit FDA 60xx is certificated and subjected to EN 298/230. Installation and handling of the burner control unit FDA 60xx by authorised specialists only.

### Advice for cable laying outside the switchboard:

- The distance between ignition transformer and burner should be not more than 2 meter.
- The ionisation cable can be up to 75 meter long, if an ignition cable is used.
- Don't lay the ignition cable in a metal tube or pipe.
- Under no circumstances you should lay the ignition and the ionisation cable together.
- In general, unshielded cores shouldn't be in a cable together with the feeder cores.
- Separate laying of measuring- / data cores and high voltage current cores or cables.
- There has to be a good protection earth (ground) connection between burner and transformer box.

### Advice for the installation inside the switchboard:

- Electronically components should be installed in shielded areas, according to there sensitivity.
- Don't install the burner control unit FDA 60xx close to a frequency converter or transformers.
- If a power transformer is used, we advice a power transformer with shield winding.
- Valves, contactors, relays and ignition transformers must have a protective circuit as follows:
  - DC voltage: recovery diode;
  - AC voltage: RC-combination / varistor parallel to the coil;
- Earthing measures:
  - Decide on a adequate central earth point, which receives all earth cores and shields.
  - In an exceptional case it could be necessary to lay the shield on a separate terminal block.
  - The cross-section of an earth core must be big enough.
  - A loop laying of an earth core must be avoided.
  - Every earthing must be direct on the central earth bar and on the feeder earth.

### Before initial start-up of burner control unit FDA 60xx check the following:

- The phasing of voltage must be adhered.
- Has the burner control unit got fluctuation of temperature, otherwise it is for seeing, that no condensation water arose.
- Is the voltage supply identical to the specification on the burner control unit (link on the blank).
- Under no circumstances pull out the burner control unit during operation.