

Thermocompressors for the paper industry

Controllable steam jet compressors for the
pulp and paper industry



Körting

HANNOVER AG

THE
EJECTOR
COMPANY

Technology for pulp and paper

Thermocompressors for the pulp and paper industry ensure drying cylinder drainage in paper-machine drying sections or compression of low-pressure steam to be used in steam supply networks. They are almost exclusively used in a pressure range that exceeds atmospheric pressure. Due to their design as versions that are controllable with a nozzle needle, Körting thermocompressors can respond flexibly to a wide range of operating conditions. Savings in steam consumption also drastically cut operational costs.

How they work

Thermocompressors are part of the group of jet ejectors and don't require any mechanical drives. Instead they use the energy of a flowing medium under pressure to generate a pumping action. Steam usually acts as the motive medium in thermocompressors.

High-pressure steam is released in a motive nozzle to bring it up to the maximum velocity. At the same time, the pressure on the nozzle's outlet drops so that the steam that requires compressing is suctioned in. When the two flows are combined in the mixing element downstream, some of the motive flow's kinetic energy transfers to the suction flow. The mixed flow is then slowed down in the subsequent diffuser and an increase in pressure occurs at the same time. This steam mixture can be used again in the process afterwards at the higher pressure level.



Körting thermocompressor in a paper factory



Advantages

The many advantages of Körting thermocompressors for the pulp and paper industry:

- long service lives
- low steam consumption due to controllable motive steam
- quick to adapt to changing conditions in the plant
- little maintenance required
- exceptionally reliable
- easy to operate
- high-quality manufacturing based on global design codes (i.e. AD 2000, Manufacture Licence ML [China], TR [Russia] or ASME [US] and others).

Excellent flexibility when retrofitting the plant

Paper machinery is operated for a period of 30 years and more. Should operating conditions change or the plant be retrofitted, Körting thermocompressors can be adapted to suit the new parameters. As a result, the thermocompressor will

continue to operate reliably even after a plant has been redeveloped. This cuts the investment costs of any retrofitting project and ensures that production can continue efficiently.

Perfect operation thanks to a precise design

Only a thermocompressor designed to handle its entire operating range can guarantee that the plant operates trouble free. Which is why Körting Hannover AG bases its designs on characteristic curves that were created in its own test field. This expertise has evolved over many decades in Körting Hannover AG's research- and development-department and analysed with software developed in-house. CFD calculations (Computational Fluid Dynamics) complement the results of the tests. These allow Körting to optimise the flow channel, but can't

replace the complex recording of characteristic curves in the test field. These skills make Körting thermocompressors leading products internationally.

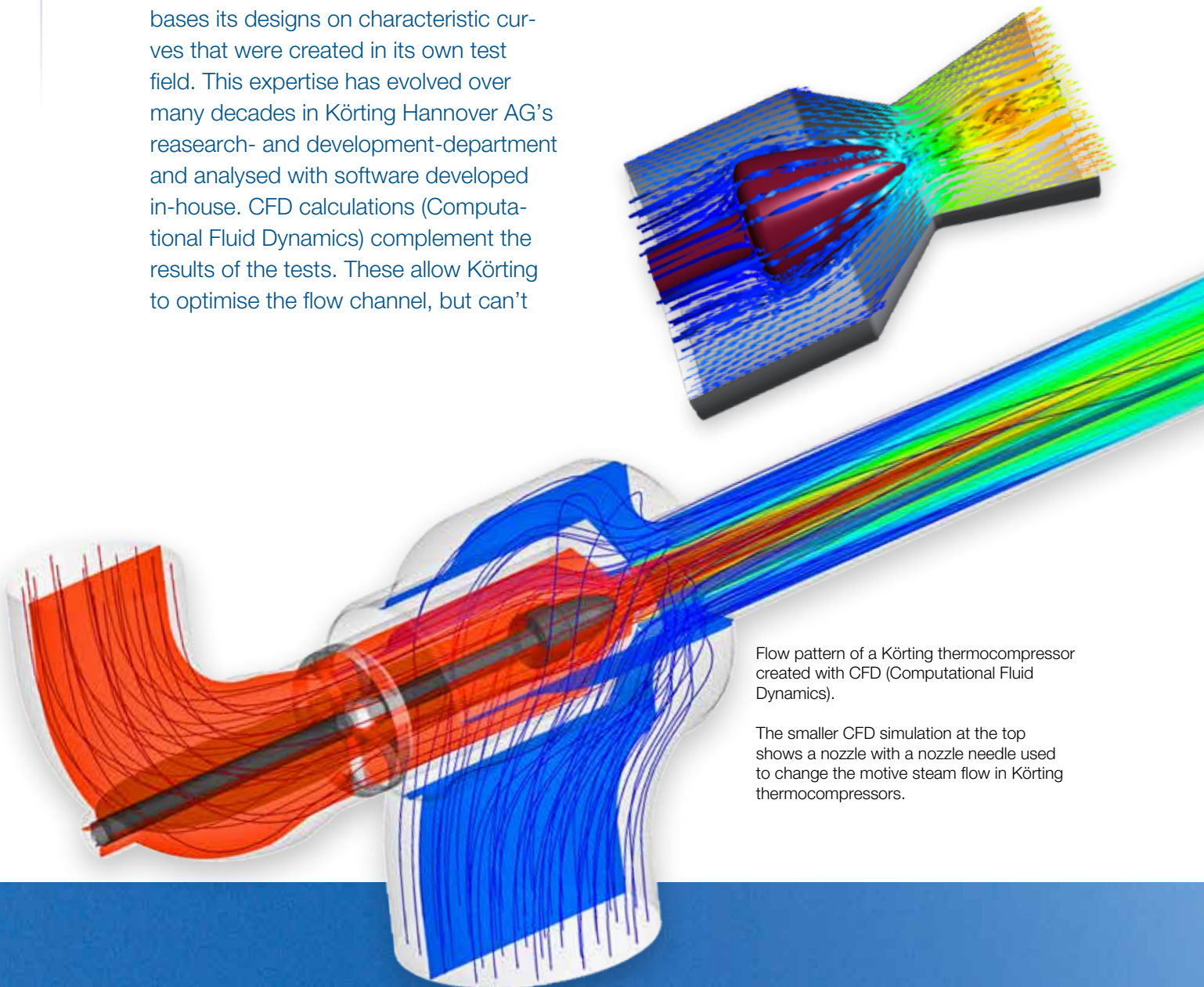

Flow pattern of a Körting thermocompressor created with CFD (Computational Fluid Dynamics).

The smaller CFD simulation at the top shows a nozzle with a nozzle needle used to change the motive steam flow in Körting thermocompressors.

Controllable nozzle needle

In order to expand the operating range, Körting thermocompressors come as controllable versions with adjustable nozzle needles. Therefore, it's possible to change the motive steam flow without having an impact on the motive pressure.

In the part load range this sometimes means huge advantages in terms of motive steam consumption compared with a solution requiring an external reduction in the motive pressure using a separate control valve.

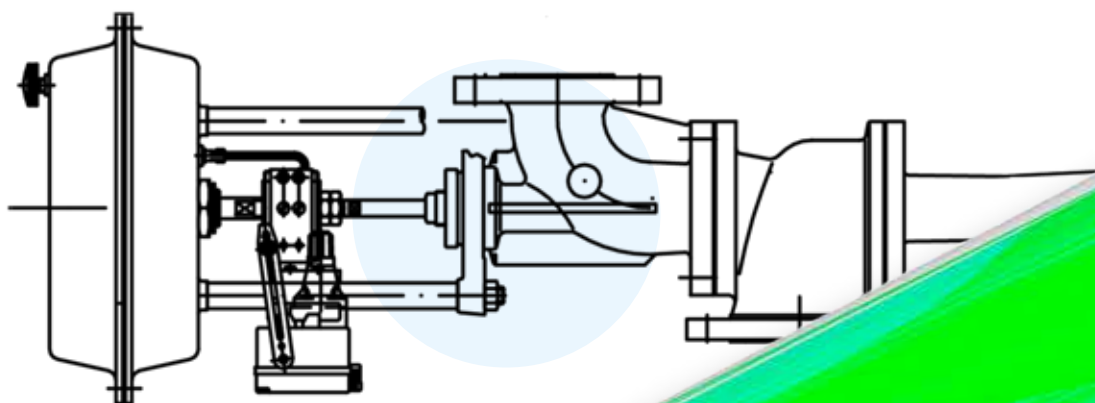

Materials

Thermocompressor are made of the following materials:

- GJS (cast iron)
- carbon steel
- stainless steel



Körting thermocompressor installed at a paper machine



Thermocompressors in Körting Hannover AG's workshop

Applications

Drying sections in paper machines

In a paper machine's drying section, the moist sheet of paper is conveyed over one or several drying cylinders. These cylinders are heated from the inside with steam. Their hot surfaces cause the water to evaporate, thus drying the paper. The heating steam condensate can't remain in the drying cylinders. An increasing film of condensate impairs the transfer of heat and causes energy consumption to rise. The condensate is expelled with a certain amount of steam from the cylinder (blow-through steam) so that the condensate can overcome the static height of the bottom edge of the cylinder to the hub and the centrifugal force.

Multi-cylinder paper machines

The multi-cylinder machines used to make fine paper and cardboard have several drying cylinders that are often combined to form dryer sections. Steam and condensate are separated downstream each dryer section and the steam continues to flow to the next dryer section (a cascade system). The condensate is expelled via rotating

or non-rotating siphons. Thermo-compressors can also be operated in stand-by mode. Thermocompressors are only used in intermittent mode if the pressure has to be decreased or increased for operational reasons.



Combined cascade and circulation system

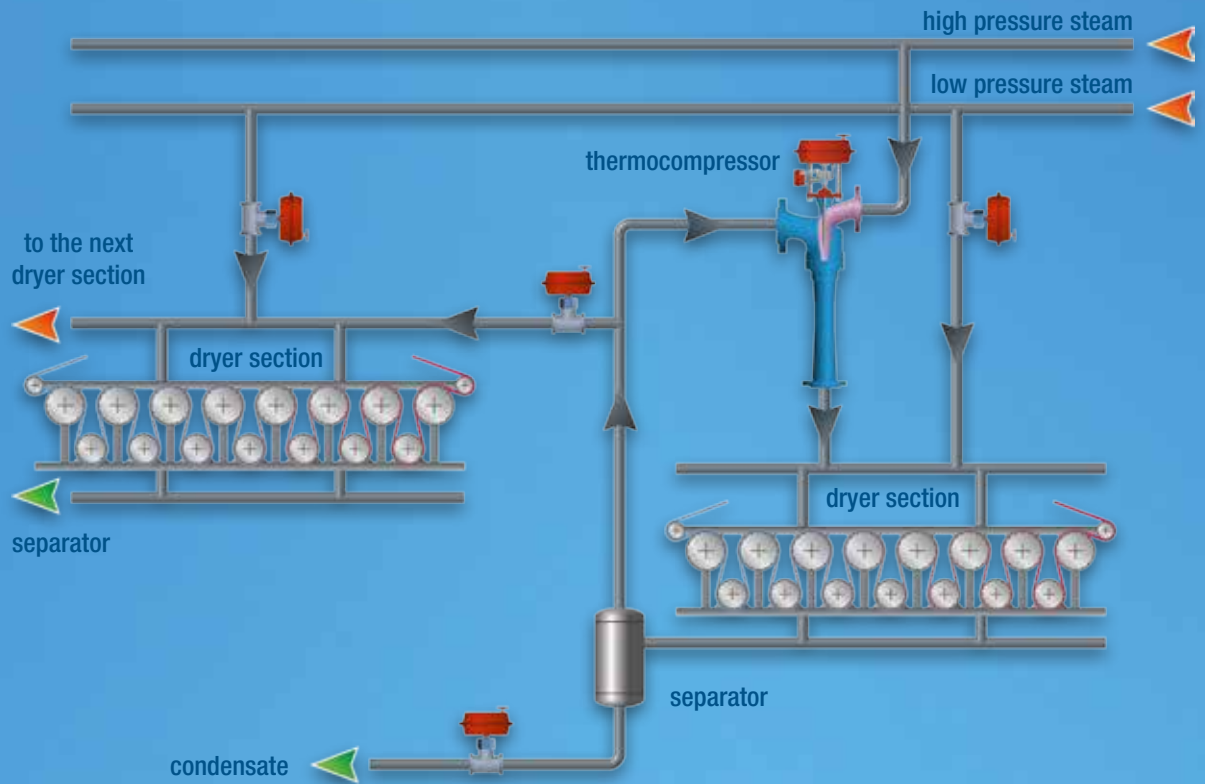

Pressure increase of turbine exhaust steam

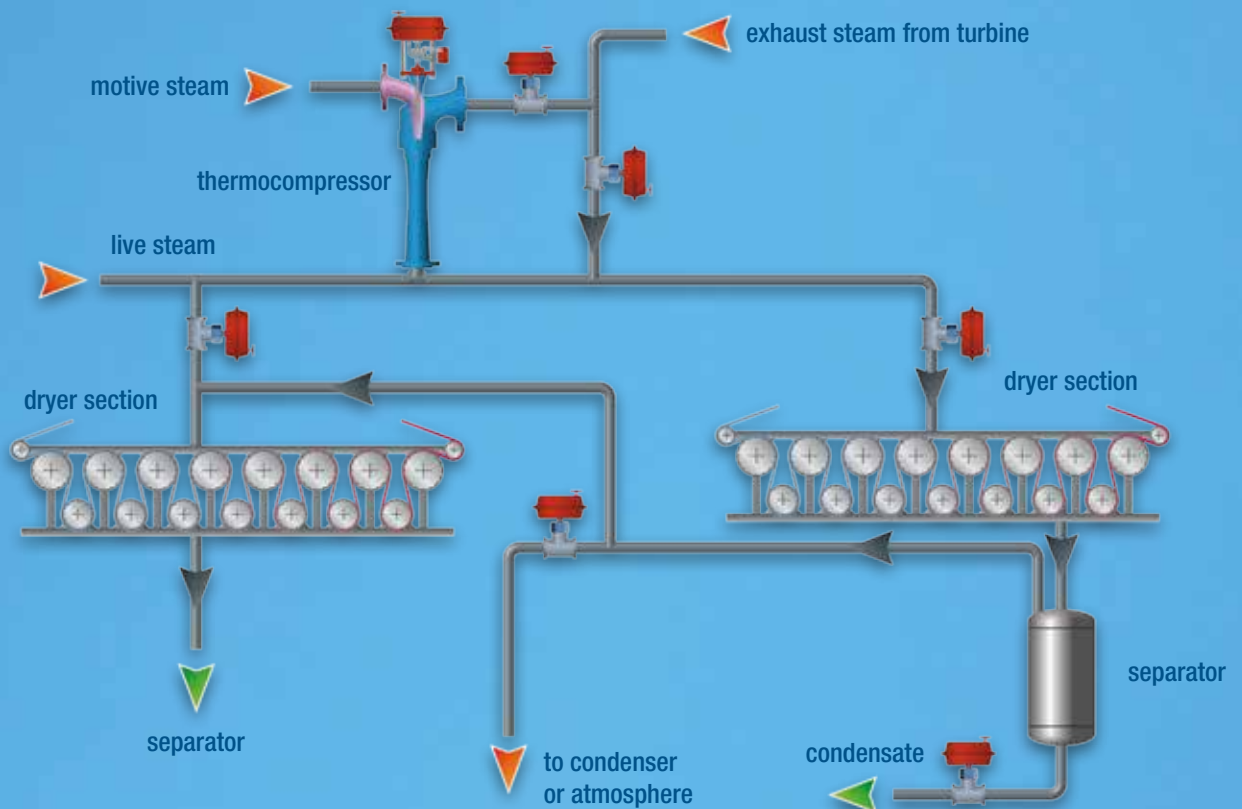

Single-cylinder paper machines

Single-cylinder paper machines are used to produce hygienic paper. These have one single large drying cylinder that can be several metres in diameter and length. These are often called “Yankee cylinders” too. Good heat transfer and even temperature distribution over the entire surface of the drying cylinder are important for the drying process. As a result, consistent removal of the condensate from the cylinder is vital and achieved with the aid of blow-through steam. This steam is compressed by Körting thermo-compressors and circulated in a closed loop.

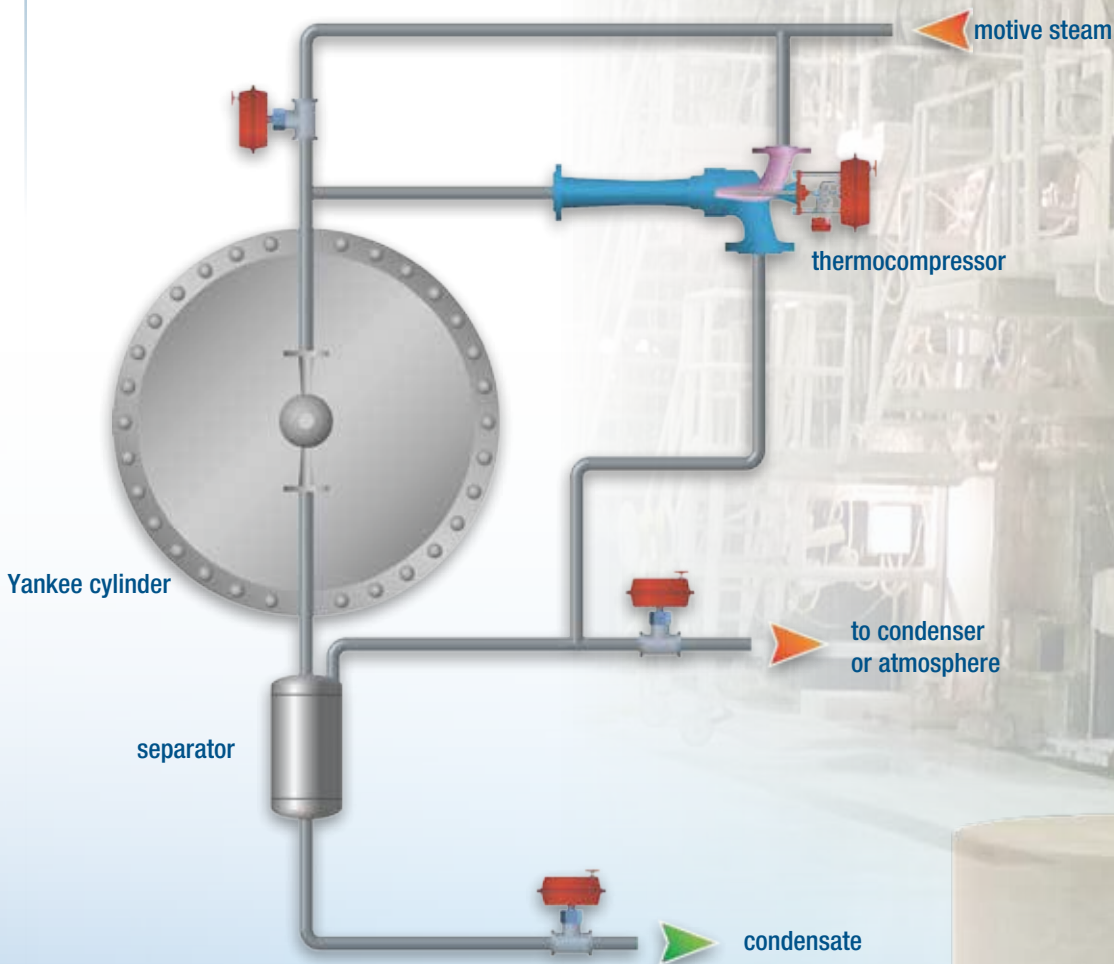

Low-pressure steam supply networks

Used as heat pumps, thermocompressors can compress low-pressure steam so that its pressure increases. Afterwards, the higher pressure steam can be fed into a dryer section or a central steam network or used again in other processes.

Utilisation of flash steam for the steam box

Steam boxes are used to speed up the drying process. The dry content is achieved due to better drainage performance in the press. The drainage capabilities of a steam box are significantly increased due to a rise in the pulp sheets' temperature and the associated reduction in the viscosity of the water. Raising the temperature by 10 °C is sufficient to create this effect. Körting thermocompressors can utilise blow-through and flash steam to use them as thermal energy in the steam box. The result is a cut in operational costs, or a rise in production with the operational costs staying the same.

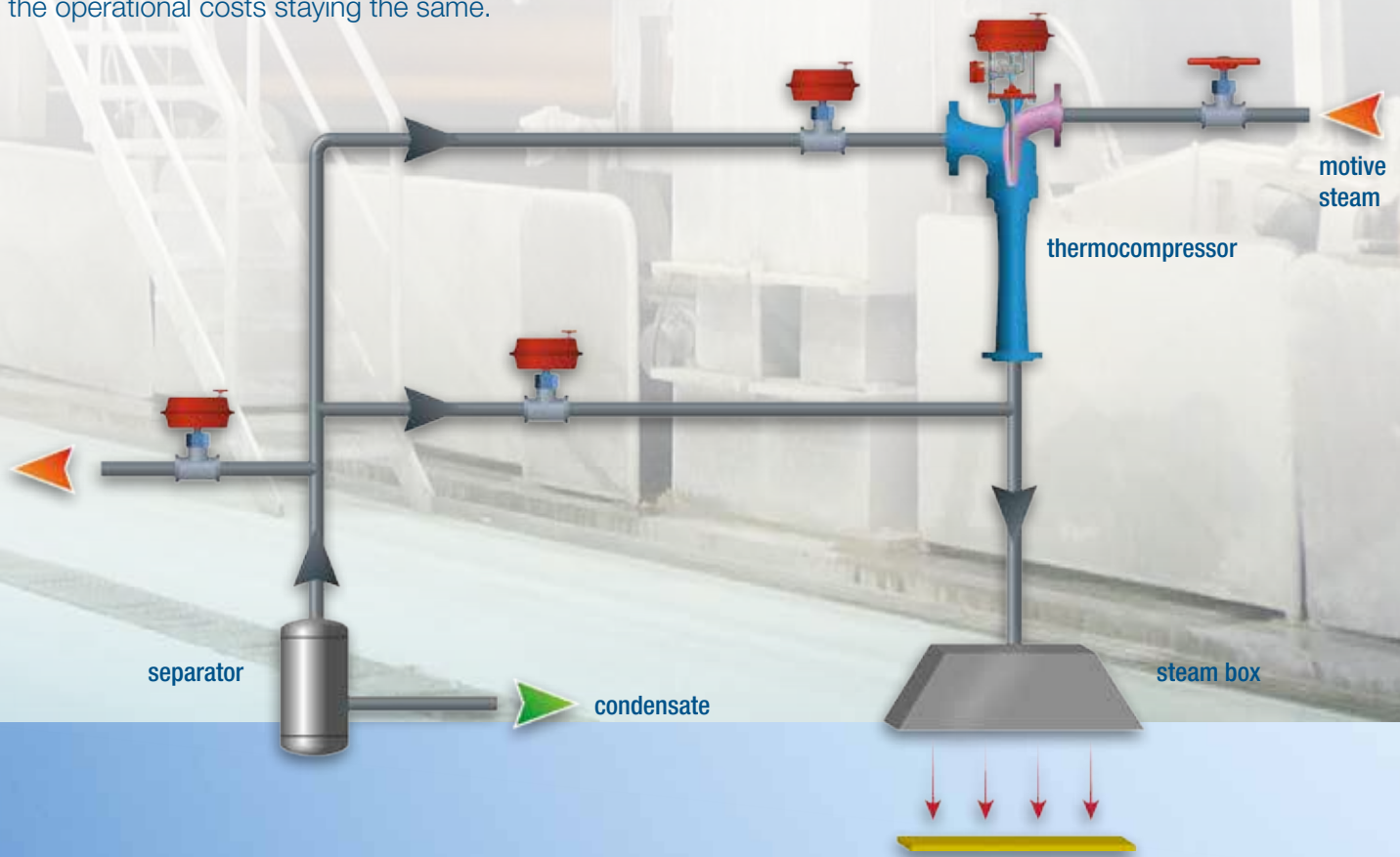

More Körting products for the pulp and paper industry

In addition to thermocompressors, Körting also has other products in high demand by the pulp and paper industry.

Steam jet gas compressors in pulp production

Körting steam jet gas compressors are ideal for extracting sulphurous gases generated during pulp production (CNCG - concentrated non-condensable gases).



Steam jet heaters

Körting steam jet heaters heat up water with steam, which condensates directly into water; they operate quietly even with alternating loads of steam and water. Their excellent design makes them efficient and effective.



Waste water aeration with Körting ejectors

Virtually every industrial park has sewage plants to clean or treat the process waste water created there. Extremely high concentrations of calcium carbonate can occur in the pulp and paper industry in particular. These place special demands on the aeration systems. Körting's oxygen transfer systems are ideal in this case, operate constantly and efficiently, even if the sewage contains a high content of dry solids.



Cooling with steam: steam jet chilling plants

Körting's steam jet chilling plants use exhaust steam or industrial waste heat to produce cold water. They don't require gases harmful to the climate as they use water as refrigerant and are therefore especially eco-friendly.



Detailed information and practical questionnaires in order to request a quote quickly are available at

www.koerting.de



FED s.r.l.

Via dei Valtorta, 2
20127 MILANO
Italy

Tel.: +39 02 26826332
Fax: +39 02 26140150
E-mail: fed@fed.it

www.fed.it