

# Multi-stage steam jet vacuum systems

Technical vacuum up to 0.05 mbar



**Körting**

HANNOVER AG

THE  
**EJECTOR**  
COMPANY

# Multi-stage steam jet vacuum systems

## Ideal solutions for any application

There is virtually no limit to where multi-stage steam jet vacuum systems in the processing industry can be used. Depending on the application, a wide range of variants of these systems are applied. The intermediate condensers are typical features of virtually any multi-stage steam jet vacuum system. The number of booster ejectors (1-, 2- or 3-stage) before the first intermediate condenser depends on the process vacuum required, the cooling water conditions and the motive steam pressure. Sometimes a pre-condenser can be used to enhance the vacuum system. The design of the intermediate condensers determines the entrained steam proportion with the departing inert gas. This mixture is compressed further within the next following jet ejector stage.

Körting Hannover AG has a worldwide leading position in designing and manufacturing multi-stage steam jet vacuum systems. The company has been developing and supplying technical vacuum equipment since it was founded in 1871 by Ernst Körting. By providing process-related designs and reflecting technical and financial parameters, an enhanced system is developed for any application.

The design of Körting steam jet vacuum ejectors is based on particularly thorough characteristic diagrams developed on in-house test rigs over several decades. Until today there are still no theoretical or numerical calculation methods for designing steam jet vacuum ejectors. The high quality of Körting's in-house design data base is crucial in order to ensure that the design of the steam jet vacuum ejectors is safe and economical. The vast amount of measuring data provides a solid base for designs which push the technology to its limits. As a result, very low motive steam pressure (even waste steam < 1 bar [abs.] is possible), or very high compression ratios (up to 16:1) are feasible.

2-stage steam jet vacuum system with surface condensers made of graphite and Hastelloy





← **Advantages**

**Körting steam jet vacuum systems provide extensive advantages:**

- no mechanically moveable parts
- besides standard materials a wide range of special materials can be used for manufacturing ejectors
- maintenance-free operation
- top levels of availability (even after lengthy downtime)
- very reliable in all respects (e.g. no risk of cavitation)
- little safety technology and process monitoring are required
- hermetically sealed, without any additional devices needed
- no potential sources of ignition, therefore the EU explosion directive ATEX must not be applied

# Process management in multi-stage steam jet vacuum systems

The fouling of the processing media is one of the aspects that governs the process design, especially the choice of the condensers. The type of process design and the choice of materials are adapted to suit the requirements in each single case.

## The key characteristics of process design in steam jet vacuum systems are:

- mixing condensers or surface condensers
- mixing condensers with cooling water or process medium
- steam jet vacuum systems with mixing condensers and closed cooling water cycle (not susceptible to soiling and little waste water is produced)
- surface condensers with condensation on the shell side or on tube side
- surface condensers with fixed tube sheets, or removable tube bundles (floating head or u-tube design)
- unheated, partially heated or fully heated steam jet vacuum ejectors
- steam jet vacuum ejectors with steam or organic vapours as the motive medium
- the quality of the materials in the systems is primarily driven by how corrosive the media used is; in addition to all grades of steel and stainless steel, high-alloy materials, or graphite, or suitable coatings are used

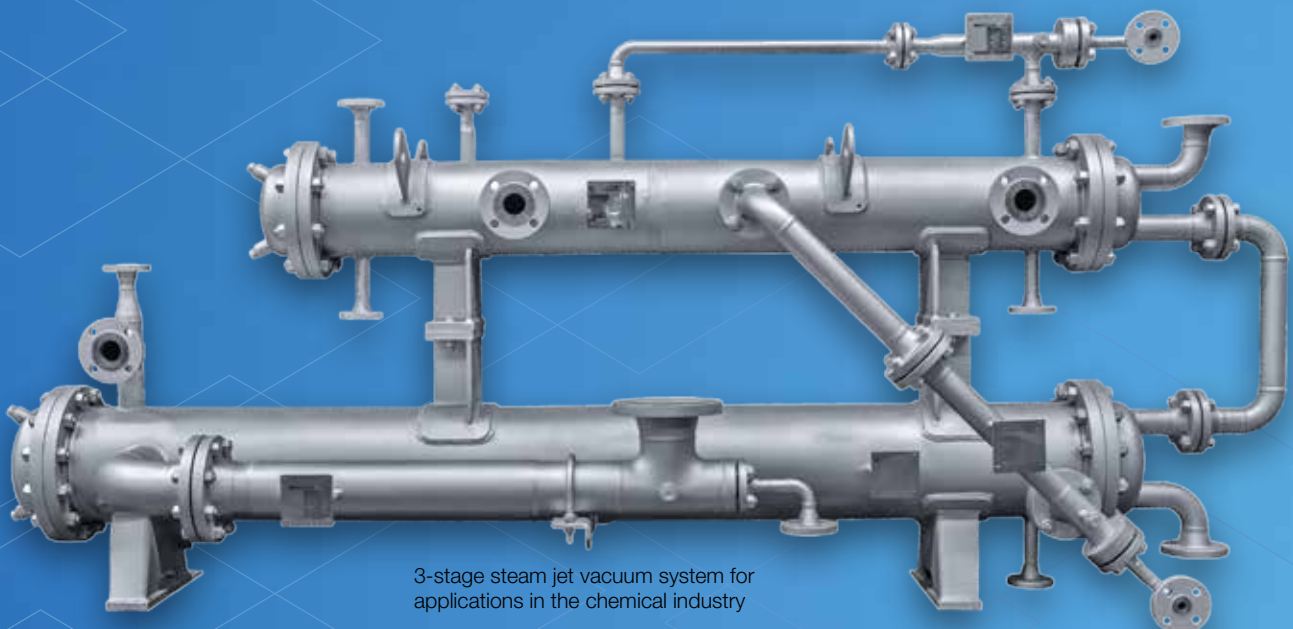

3-stage steam jet vacuum system for applications in the chemical industry

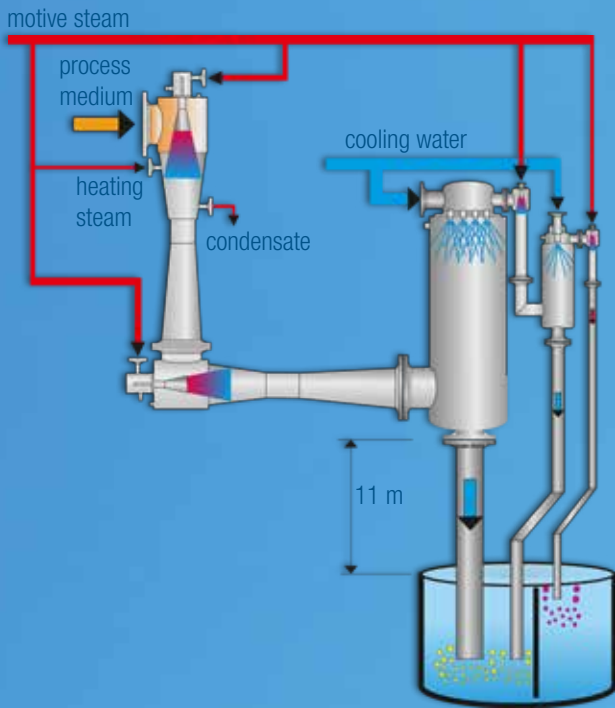

In this **4-stage steam jet vacuum system with mixing condensers**, two ejector stages are connected in series. These compress into a main condenser. Afterwards two additional ejectors evacuate the main condenser. An intermediate mixing condenser condenses the motive steam of the third ejector stage. Such a vacuum system can reach a suction pressure below 1 mbar, depending on the cooling water temperature in the first mixing condenser.

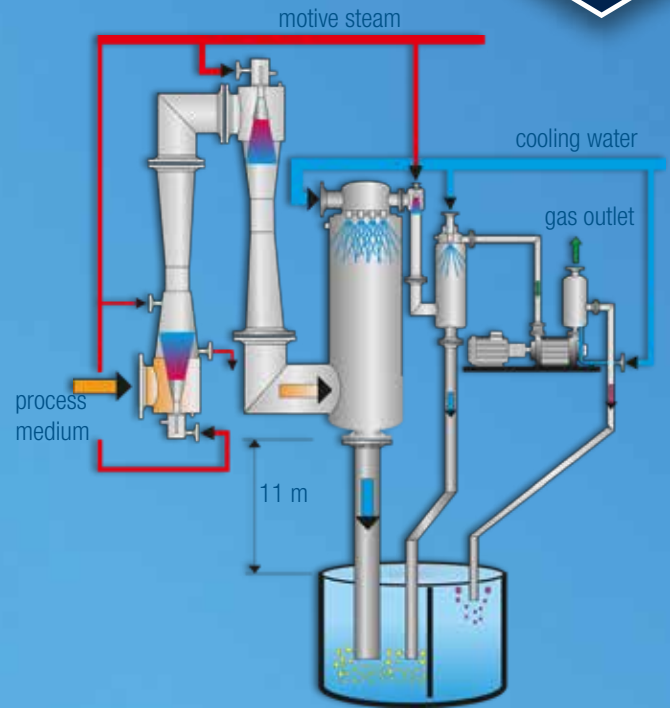

The flow sheet shows a **4-stage vacuum system with mixing condensers**. The last stage of the vacuum system is a liquid ring vacuum pump. The liquid ring vacuum pump evacuates the intermediate mixing condenser to atmospheric pressure. The use of mechanical pumps can help to reduce the motive steam consumption. Such a system of jet ejectors and a mechanical vacuum pump is called a hybrid system.

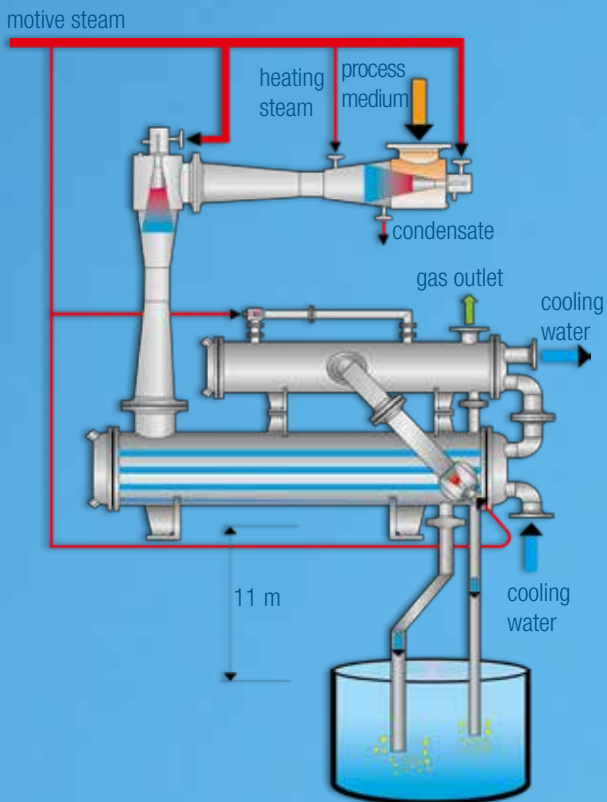

The flow sheet above shows a **4-stage steam jet vacuum system with surface condensers**. In this example, two ejector stages are series connected in order to achieve a suction pressure of 1 mbar. Two additional ejector stages compress the non-condensable components of the suction flow from the first surface condenser to atmospheric pressure. In the intermediate and subsequent surface condensers the motive steam of each upstream ejector is condensed.

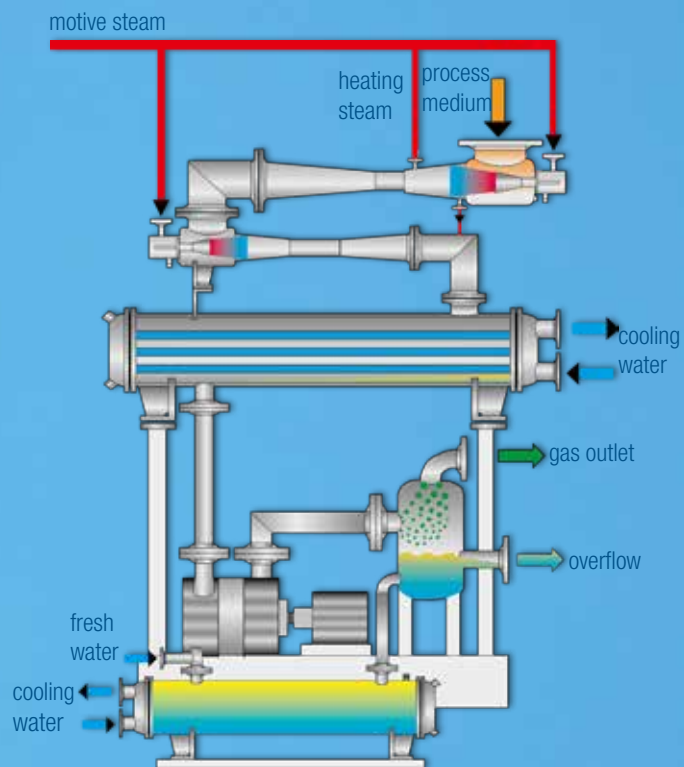

This is a **3-stage hybrid vacuum system with surface condensers**. The surface condenser is evacuated by a liquid ring vacuum pump. This mechanical pump forms the last stage of the vacuum system. Through the use of steam jet vacuum ejectors and mechanical vacuum pumps this vacuum system is called a hybrid system.

# Choice of venting systems

## A hybrid system or multi-stage steam jet vacuum system as a venting unit

Each vacuum system must compress a certain amount of inert gas to atmospheric pressure, at least the amount of leakage air into the system. In a multi-stage steam jet vacuum system, the venting unit (or venting stage) has to compress the vapour-saturated inert gas from the main condenser to the atmosphere. The amount of vapour in the inert gas is determined by the sub-cooling of the mixture achieved below to the saturation temperature in the condenser.

The decision whether to choose a liquid ring vacuum pump or a single- or multi-stage steam jet vacuum ejector as a venting unit has to be based on the process conditions. The advantages of using a liquid ring vacuum pump as a venting stage are its low energy consumption, low amount of waste water and its better start-up evacuation times. The benefits of a steam jet vacuum ejector as a venting unit include its reliability and the fact that it doesn't soil easily. In the end, the financial and technical parameters need to be weighed up when deciding whether to use a multi-stage steam jet vacuum ejector or a liquid ring vacuum pump.

When liquid ring vacuum pumps are used as venting units, such systems are often referred to as hybrid systems. Körting enhances its hybrid systems by carefully designing individual components together, the steam jet vacuum ejectors, condensers and liquid ring vacuum pumps. This is vital in closed process water cycles with soluble components and when condensate is conducted through the liquid ring vacuum pump.

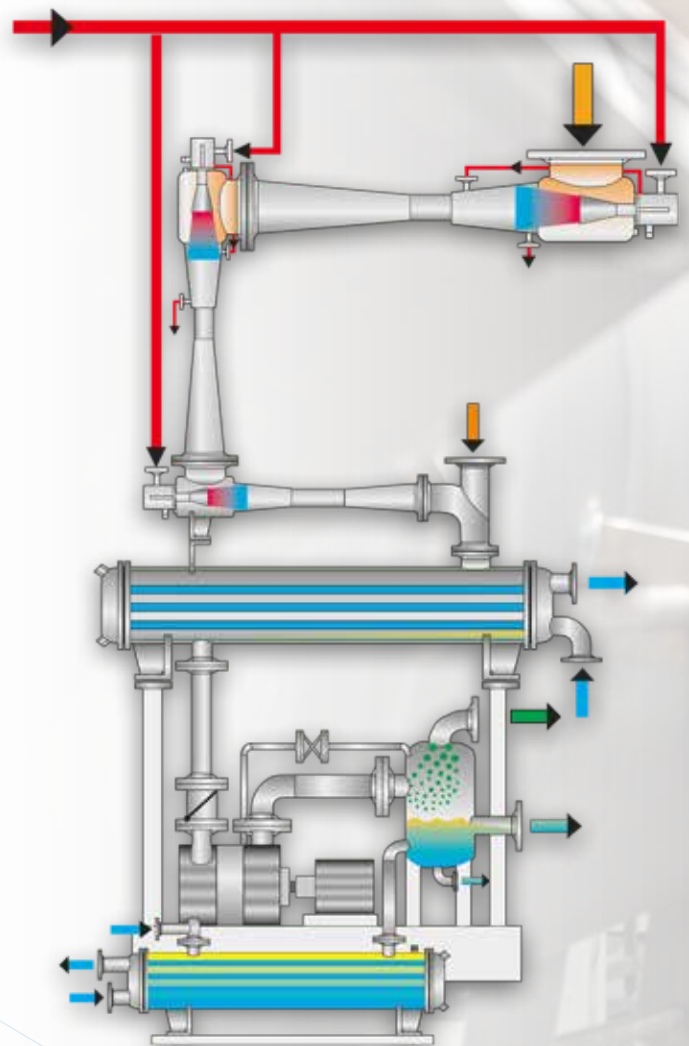

4-stage steam jet vacuum system with surface condensers and liquid ring vacuum pump as final stage.



Hybrid system consisting of two steam jet vacuum ejectors with a surface condenser and a liquid ring vacuum pump



## Criteria for selecting the venting system

liquid ring  
vacuum pump

steam jet  
vacuum ejector

small amount of inert gas

high-volume batch operation

soluble components with high vapour pressure

no barometric height available

toxic or explosive components

# Control of multi-stage steam jet vacuum systems

Two different goals must be borne in mind:

- 1. suction pressure control**
- 2. minimising motive steam consumption depending on the cooling water temperature**

In both cases, the control options depend on the compression ratio of the steam jet vacuum ejectors. If the compression ratio is below 3:1, both the discharge achievable pressure and the suction pressure can be controlled by adjusting the motive flow.

The motive steam flow can be adjusted by reducing the motive steam pressure or by changing the cross-section of the motive steam nozzle by means of a nozzle needle. In terms of energy, the nozzle needle control is superior to just reducing the pressure because nozzle needle control always exploits the maximum expansion ratio throughout the motive steam nozzle. The lower the motive steam pressure is, the greater the benefit. In multistage steam jet vacuum systems compression ratios greater than 3:1 are customary at each of the individual stages. These compression ratios always cause sonic velo-

city to occur in the smallest cross section of the diffuser. As a result, decreasing by throttling decreases the achievable discharge pressure of the steam jet vacuum ejector which results immediately in an unstable operation of the whole vacuum system.

Therefore, where large compression ratios exist, the motive flow can only be reduced if the outlet pressure required (usually the condenser pressure) allows this to happen. So, the purpose of throttling motive pressure or using nozzle needle control is only to optimise motive steam consumption depending on the temperature of the cooling water. These measures cannot be used to control the suction pressure.



Controllable steam jet vacuum ejector, double compression





Process-vapour operated 3-stage vacuum system with mixing condensers

## As a result, where large compression ratios are present, the vacuum is controlled by:

- throttling the suction flow (only for small capacities)
- adding motive steam (ballast steam) to the suction flow (only where small control ranges apply)
- returning mixed steam from the discharge to the suction side of the steam jet vacuum ejector (possible to an unlimited extent)



For chemical processes designed 2-stage steam jet vacuum system with surface condensers



3-stage steam jet vacuum system made of graphite mounted on a base frame

# Motive-steam requirements of multi-stage steam jet vacuum systems

Motive steam requirements for a particular application are calculated when designing this type of system. The following information must be observed as regards motive steam requirements in steam jet vacuum systems.

First of all, a distinction must be made between high compression ratios where low suction pressure is concerned and relatively low compression ratios within the venting unit.

High compression ratios for suction pressure below 10 mbar abs.) are usually in the range of 10:1. As a result, 2.0 kg/h up to 3.0 kg/h motive steam have to be applied for 1.0 kg/h air-equivalent suction flow. Here the motive steam pressure has relatively low influence (above 4 bar). Because in the case of low suction pressure the expansion ratio in the motive steam nozzle is always supercritical to the extent that at the end of the Laval nozzle part of the steam jet vacuum ejector multiples of sonic velocity are achieved. As a result, the impact of the motive steam pressure (between 4 bar and 10 bar) on motive steam consumption is fairly low (less than 25 %) for low suction pressure.

For standard compression in the range of 3:1 to 4:1 in the venting unit, 1.5 kg/h to 3.0 kg/h of motive steam for 1.0 kg/h of air-equivalent suction flow have to be applied for each steam jet vacuum ejector

stage. The motive steam pressure has a higher impact on motive steam consumption. In this case the motive steam pressure (4 – 10 bar) has an impact on motive steam requirements of up to 60 %. As the real suction flow of a vacuum ejector can consist of various gases and vapours, it is usually converted into an equivalent air load. einen äquivalenten Luftstrom umgerechnet.

Körting Hannover AG offers a range of different solutions to calculate the air equivalent of an actual suction flow.

On [www.koerting.de](http://www.koerting.de) a calculation program is available. Alternatively, the Körting reference data hand-outs can also be used.

The maximum cooling water temperature for the intermediate condensers has a major impact on the motive steam requirements of a particular application for steam jet vacuum systems.

Higher cooling water temperatures mean higher compression ratios and therefore greater motive steam consumption. As a result, a cooling water temperature that is 5 °C higher can easily lead to 30 % more motive steam consumption.

Körting Hannover AG's quotes for steam jet vacuum systems include detailed information on the motive steam and cooling water requirements and consumption.



# In-house manufacturing of jet ejectors and condensers

Because the jet ejectors and condensers are manufactured in the Hannover workshop, process-enhanced designs can be quickly turned into efficient systems of top quality. All standard types of carbon steel and stainless steel can be used, as well as high-alloy stainless steels, duplex steels, other special materials (like Hastelloy, titanium or graphite) and plastic materials.



## Körting Hannover AG's manufacturing facilities are certified to:

- DIN EN ISO 9001 : 2015
- AD 2000 HP0
- DGRL 2014/68/EU
- Manufacture Licence ML (China)
- ASME-U-Stamp (USA)
- TR (Russia)

# In-house research and development

Being a manufacturer of leading solutions in vacuum and environmental technology requires application-driven research and development. It forms the basis for continuous improvements and is an essential precondition for the launch of new technical solutions.

## Test rigs and facilities

Test rigs and facilities are also available for almost all Körting products and components. In addition, test facilities are available for optimising and adapting to special conditions. The customer directly benefits from the results of these extensive services.



Performance test of three series connected steam jet vacuum ejectors with a suction pressure of 0.1 mbar



FED s.r.l.

Via dei Valtorta, 2  
20127 MILANO  
Italy

Tel.: +39 02 26826332

Fax: +39 02 26140150

E-mail: [fed@fed.it](mailto:fed@fed.it)

[www.fed.it](http://www.fed.it)