

Cooling – scrubbing – conveying with Körting jet scrubbers



Körting

HANNOVER AG

THE
EJECTOR
COMPANY

Jet scrubbers

from planning to commissioning

Jet scrubbers are used for the following basic processes:

Cooling – absorption – dedusting - conveying

The gas enters the jet scrubber from the side. The motive fluid acts as a scrubbing medium and **direct current** injects it to the gas and into the scrubber. The gas is accelerated due to the impulse exchange with the motive fluid.

This results in **conveying flow**, enabling an **increase in the gas pressure**. Depending on the design of the plant, this rise in pressure means that the internal flow resistance of the plant and the resistance in adjacent pipes can be overcome. Therefore, the jet scrubber replaces

a mechanical ventilator in many cases.

The level of power transmission manifests itself in a jet scrubber's pressure gain.

Because the scrubbing medium is sprayed through nozzles, the cylindrical section of the scrubber is filled with a full cone and reaches the **large phase interface area between the gas and the liquid** which is required for the basic operations.

Advantages of Körting jet scrubbers

Jet scrubbers have a number of advantages:

- simple designs
- little maintenance required
- high levels of reliability and availability
- no fire risk in the scrubber
- a combination of gas conveying with dedusting and absorption

A typical Körting jet scrubbing plant consists of:

- jet scrubber
- separation tank
- swirl droplet separator (DTA)

These components all play a part in the process as a whole:

The jet scrubber conveys, absorbs, dedusts and cools the gas with the aid of the scrubbing medium.

The scrubbed gas and the liquid phase are separated from one another in the separation tank. At the same time the tank acts as a buffer before the scrubbing liquid is distributed.

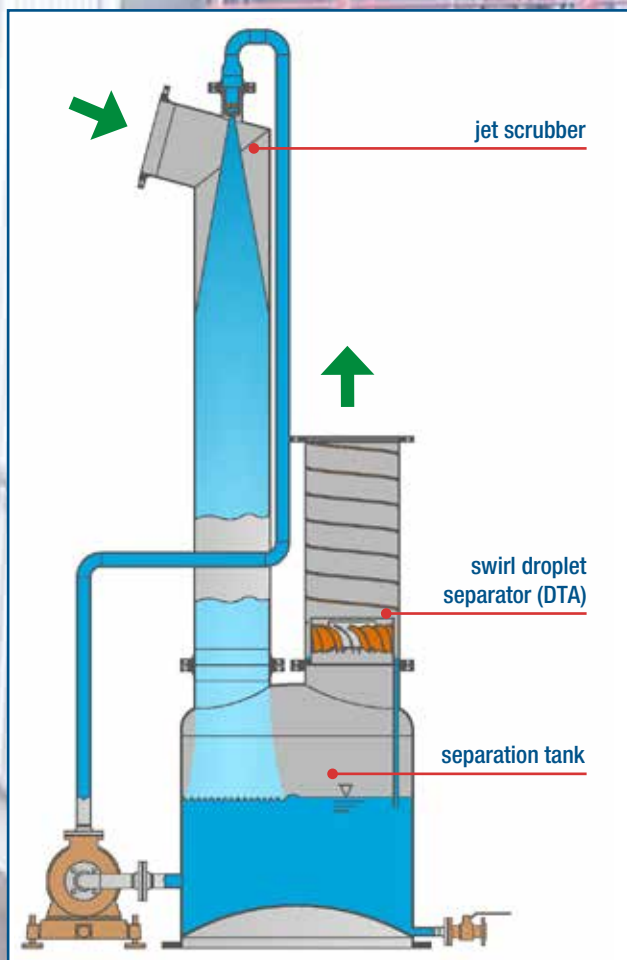

The downstream swirl droplet separator is used to separate the fine droplets caught in the gas flow.

Depending on the engineering requirement, further components can also be added.

Environmental regulations are complied with and substances can be recovered from gases by using single or multi-stage jet scrubbers, also in combination with packed towers.



Vent Gas Treating System (VGTS)

The Vent Gas Treating System is a complete unit which includes jet scrubber, separation tank, packed tower and swirl droplet separator and is fully mounted in a steel structure. The objective of the system shown is to remove hydrochloric acid, chlorine and sulphur dioxides from a hot processing flow. The plant is designed for gas inlet temperatures of 530 °C. By using caustic soda (10 % NaOH) and sodium hydrogen sulphite (20 % NaHSO₃) as scrubbing fluids all absorbed components can be removed from the waste gas. As required by statute (German TA Luft regulation) the gas emissions are scrubbed and can be released into the atmosphere.

Applications

The self-priming jet scrubber is superb for:

- **conveying gas** without mechanical ventilators
- direct **gas cooling** (quenching)
- physical and chemical **absorption of harmful substances** (SO₂, Cl₂, HCl, NH₃, HF, H₂S, etc.)
- **removing dust** with particles over 3 µm in size
- **recovering** substances from gases

Sizes

The Körting jet scrubbing plants are supplied as follows:

- as standard versions of DN 80 to DN 1 000 for gas flows of 60 to 26 000 m³/h, also in combination with packed towers
- customised solutions for gas flows of 60 to 100 000 m³/h, in single or multi-stage designs

Depending on the application, combinations can be used to fulfil special conditions and requirements.

Solutions with good track records are also available for special cases, such as gas flows of up to 300 000 m³/h or gas temperatures over 1 000 °C.

Materials

- carbon steel, stainless steel
- steel with coatings: rubber, PVDF, PTFE, Halar, etc.
- plastics: GFK, PP, PVC, PVDF reinforced and non-reinforced
- special materials



ATEX-compliant
jet scrubbing plant



Badenstedter Str.56
D-30453 Hannover
Phone +49 511 2129-0
Fax +49 511 2129-223
www.koerting.de

Jet Scrubber Plant: Typ I

Körting Hannover AG

04.15

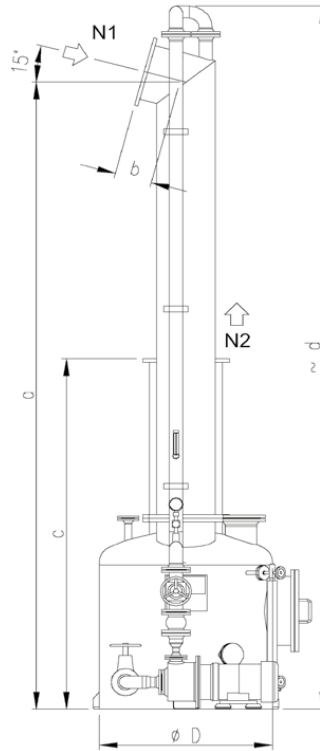
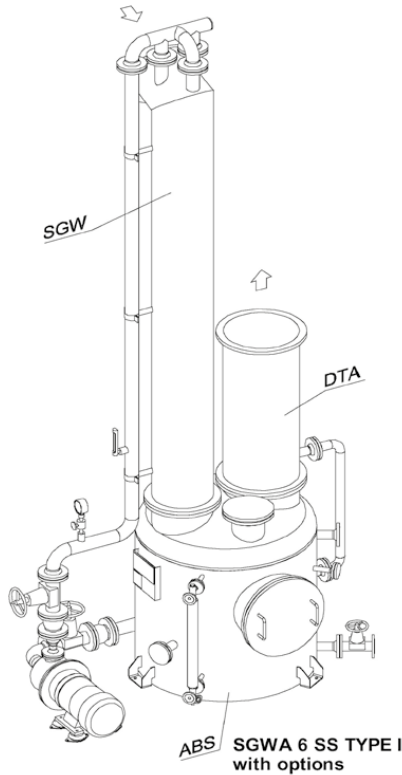

EXECUTION

Material	PP
Pump	PP
Fittings	PP
Screws	A2-70
Gaskets	EPDM

FIXED FLANGES (PN 10)

Gas	EN 1092-1
Liquid	EN 1092-1

DESIGN

allow.work.temp.	80 °C
allow.work.pres.	+/-10 mbar
Corrosion suppl.	0 mm

EXECUTION

Material	1.4301
Pump	SS
Fittings	SS
Screws	A2-70
Gaskets	Klinger SIL

FLANGES

Gas	DIN 28031
Liquid	EN 1092-1

DESIGN

allow.work.temp.	150 °C
allow.work.pres.	-0,2/+0,5 bar
Corrosion suppl.	0,3 mm

SCOPE OF DELIVERY

acc.

Technical Specification

SIZE	FLOW				DIMENSIONS							WEIGHT	
	Gas		Liquid	Gas								Plant	
	norm	max		inlet	outlet							PP	C-St
	[m³/h]	[m³/h]	[m³/h]	N1	N2	D	a	b	c	d	Area	[kg]	[kg]
<input type="checkbox"/> 0	60	150	1,5	80	200 (D)	700	1980	200	1300	2300		180	440
<input type="checkbox"/> 1	100	250	2	100	250 (D)	700	2100	200	1300	2400		185	450
<input type="checkbox"/> 2	180	400	3	125	200	700	2400	200	1650	2700		190	510
<input type="checkbox"/> 3	250	600	4	150	250	700	2750	200	1750	3050		195	540
<input type="checkbox"/> 4	500	1000	5	200	300	800	3200	200	1950	3550		210	590
<input type="checkbox"/> 5	850	1650	8,5	250	350	900	3950	250	2270	4300		240	680
<input type="checkbox"/> 6	1200	2400	12	300	400	1000	4650	300	2470	5100		340	930
<input type="checkbox"/> 7.1	2200	4100	22	400	500	1200	5900	350	2870	6450		450	1430
<input type="checkbox"/> 7.2	2200	4100	22	400	500	1200	4900	350	2870	5450		460	1460
<input type="checkbox"/> 8	3400	6700	34	500	700	1600	5250	400	3380	5850		530	1860
<input type="checkbox"/> 9	5000	9100	50	600	700	1800	6300	450	3580	6850		630	2400
<input type="checkbox"/> 10	8900	17000	90	800	1000	2200	7320	550	4270	7950		1000	3730
<input type="checkbox"/> 11	13300	26000	135	1000	1200	2600	8700	650	4780	9555		1330	5210

All rights reserved within the framework or further technical development.
(SGW = Jet scrubber, ABS = Separator, DTA = Swirl droplet separator, D = Demister)

Alle Rechte vorbehalten! Nicht genehmigte Weiterverwertung, insbesondere Nachahmung oder sonstiger Mißbrauch des geistigen Eigentums wird zivil- und strafrechtlich verfolgt!

All rights reserved! Unauthorised re-use, particularly imitation or other abuse of copyright, will be subject to legal proceedings!

Remarks:



FED s.r.l.

Via dei Valtorta, 2
20127 MILANO
Italy

Tel.: +39 02 26826332

Fax: +39 02 26140150

E-mail: fed@fed.it

www.fed.it