

# Water treatment with Körting ejectors

Energy-efficient solutions – low maintenance  
and long service life



# Waste water aeration with increased efficiency

## Fields of application

Ejectors are used in many areas of water treatment. Their form and design are determined by the type of motive and conveying medium as well as by the pressures prevailing at all three ejector connections. Ejectors are self-priming and operate without any moving parts. Their method of operation is based solely on the laws of fluid dynamics.

Jet ejectors operated with water or another liquid are used to

- **mix liquids and gases**
  - as ejectors
  - and as liquid jet gas mixers
- **compress gases**
  - as water jet air compressors
  - and as liquid jet gas compressors
- **mix liquids**
  - as liquid jet mixing nozzles
- **convey liquids**
  - as liquid jet liquid ejectors

## Design of a Körting jet ejector

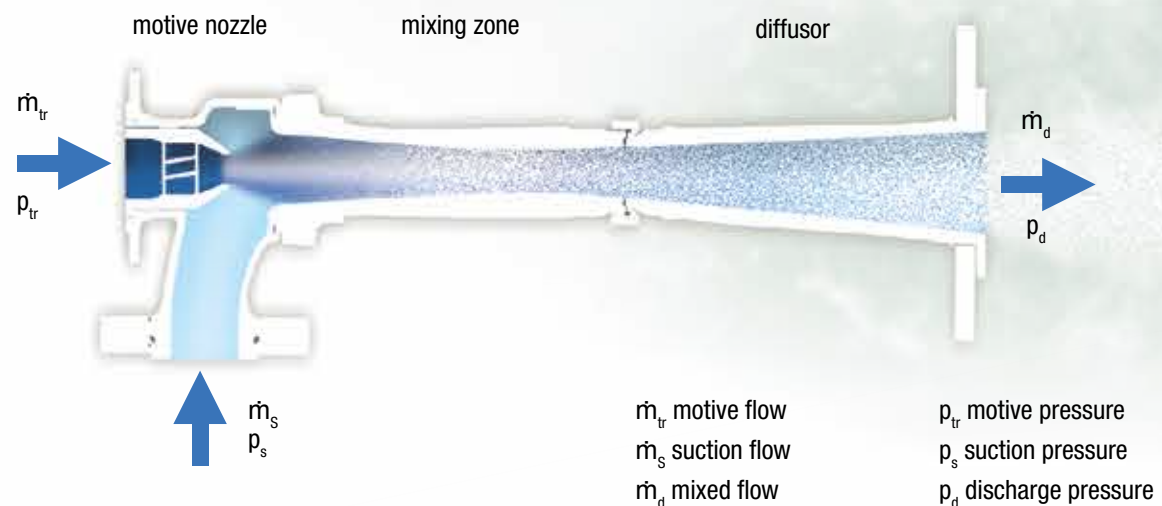

## Function

Motive medium passes through the jet ejector as shown in the cross-section. Along this flow channel the cross-section changes in such a manner that pressure in the motive nozzle drops and velocity increases. The region with the lowest static pressure is to be found just after the motive nozzle. Here the suction medium

can enter and be mixed with the flowing motive medium whereby kinetic energy from the motive flow is transferred to the suction flow. Then in the diffuser the flow is slowed down again. This action boosts the pressure up to the discharge pressure prevailing at the jet ejector outlet.

# Ideal for plants with highly polluted waste water

## Ejectors for the aeration process

In its construction form the ejector for the aeration process corresponds to that of a jet ejector. Because organically polluted wastewater requires a high amount of oxygen and also because of the increasing height of modern biological waste water cleaning plants it is energetically more efficient to pre-compress the air mechanically to the hydrostatic pressure prevailing at the installation point of the ejector and to supply it so to the suction connection. This waiving of an appreciable pressure in the ejector reduces the necessary motive pressure. At the same time, more favourable mixing ratios (suction flow : motive flow) are achieved. Motive nozzles of Körting ejectors are equipped with a non-clogging spiral. So the motive jet disperses the air already at a low motive pressure in a myriad of fine bubbles which are then mixed vigorously together with the motive flow in the mixing zone. This air/water mixture is injected into the aeration tank with a high turbulence. In this way the ejector guarantees optimum oxygen supply and a total intermixing of the tank contents. Even with a high biomass concentration in the waste water it is still possible to attain flow velocities which prevent deposits on the tank floor.

### Multi-path ejectors inside aeration tanks



### Installation from outside through the tank wall



## Advantages of Körting ejectors

- **maintenance-free**  
no moving elements
- **high oxygen efficiency**  
Fine bubbles create large contact surfaces between air and water and high turbulence renews these contact surfaces.
- **no deposits**  
The intensive jet flow directed towards the tank floor prevents deposits of biomass.
- **straightforward control of oxygen supply**
- **non-clogging construction**  
The nozzle diameter defines the narrowest flow cross-section.
- **no sealing problems**  
When the plant is inactive, water can enter the air pipeline without negative effects and when re-started, the ejector's entraining effect expels any liquid in the pipe.
- **design acc. to requirements**  
Various sizes can be designed and adapted to requirements.



# Multi-path ejectors in aeration tanks

When equipping an aeration tank with Körting ejectors there will not be any moving parts in the tank which would require maintenance. The ejector's mechanical stress corresponds to that of a pipeline with a higher flow velocity inside. Roots blowers/compressors and pumps can be installed outside the tank for easy maintenance.



## Oxygen efficiency

As oxygen transfer not only depends on bubble size (contact surface between gas and water) but to the same measure on the renewal of the gas bubble contact surfaces, ejectors – with their permanent circulation of the waste water – can so achieve a far larger oxygen efficiency than other aerators. With their inclined flow direction towards the floor Körting ejectors

utilise the respective tank depth completely as entrance depth. Extensive oxygen supply tests in pure water (EN 12255-15) acc. to the oxygen adsorption method form the data basis for designing Körting ejectors. All measurements were executed on full-scale plants and confirmed in numerous inspection tests.

## Control range and oxygen yield

Regulation of the oxygen supply is achieved solely by altering the air volume flow. A reduced air supply lowers the inlet pressure to the ejector thereby additionally reducing the power intake of the roots blower/compressor. At the same time the specific oxygen efficiency is increased. The result is a nearly constant high oxygen yield over the whole control range of the oxygen transfer system with its maximum value in partial load operation near the design point. Ejectors are designed – depending on the rheological properties of the activated sludge (temperature, dry solids contents) – for a suitable air/water ratio. The improved performance of the oxygen transfer system by simply increasing the air supply as well as its optimal oxygen efficiency in partial load operation are so guaranteed at all times.

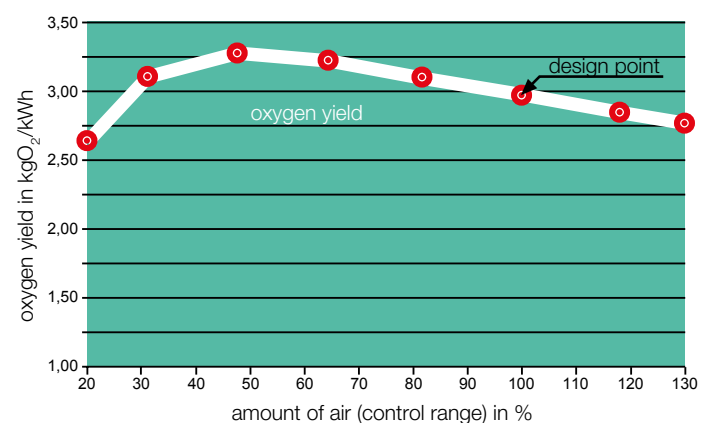

For the calculation of the standard oxygen yield practicable efficiency values have been considered for pumps and compressors (compressor:  $\eta = 0,6$  ; centrifugal pump:  $\eta = 0,75$ ).

## Design

The relatively short individual and detachable ejectors are connected to a manifold casing and supplied with motive flow from below and with compressed air from above.

The jet flow is inclined towards the floor and the angle of exit is adapted individually to the installation conditions. As material we use

polypropylene which has excellent resistance to chemical impact. For particularly demanding application conditions the motive nozzles as well as also the mixing zones can be made of chrome-nickel steel. When there are high calcium carbonate concentrations in the aeration tank the choice of materials must always be adapted to the operating conditions.



Seven-path ejectors in the 2 000 m<sup>2</sup> aeration tank of a laundry

## Installation inside aeration tanks

Once the tank geometry, water depth and oxygen requirements have been determined then number, design form and arrangement of the multi-path ejectors can be adapted to the case in question. Their mounting can be effected quite simply by two flanges in the pipelines for motive flow and compressed air.

Installation of compact units on the tank floor guarantees comprehensive aeration and complete intermixture of the waste water.





# Installation from outside through the tank wall

The ejector shown here is made of stainless steel and is mounted „through-the-wall“. Its connections for motive flow and compressed air are located outside the aeration tank.

These comparatively large units are equipped with a second downstream mixing zone in which additional liquid is sucked in, so intensifying the intermixing action in the tank.

If required, the ejector can be equipped with a shut-off device downstream of the motive nozzle so that the motive nozzle can be checked at any time without having to empty the tank.

This equipment option allows for a permanent application of the oxygen transfer system, even with extreme concentrations of calcium carbonate in the waste water. Although the relatively large ejectors are inferior regarding oxygen efficiency to our multi-path ejectors with finer air bubbles, their 100 % availability is often the decisive criterion for our customers. It is therefore not remarkable that many plants have been realised in the paper industry – sometimes also as a retrofitting action to replace inadequate installations.





1 200 m<sup>3</sup> aeration tank for waste water from the paper industry



## Oxygen efficiency

At the usual entrance depths of 5...8 m it is possible to achieve an oxygen efficiency  $OC_{20}$  in clean water of  $11 \text{ g O}_2/\text{Nm}^3 \cdot \text{m}$ . In partial load operation – at a reduced air amount – the oxygen efficiency can be boosted above this value as far as  $14 \text{ g O}_2/\text{Nm}^3 \cdot \text{m}$ .

Depending on entrance depth and oxygen requirements approx. 400 - 500 Nm<sup>3</sup>/h of compressed air can be injected into the tank by one single ejector.



# Ejectors in SBR plants

Ejectors are exceptionally suited for the aeration and intermixing of so-called „SBR“ plants (Sequenced Batch Reactor). These aeration plants (with retaining operation) in which, amongst other things, the biological processes of nitrification and denitrification take place consecutively in the same tank, require a complete intermixing of the tank contents with and without air supply. Through the installation and special arrangement of ejectors patented for this process in the SBR reactor they can be utilised for the simultaneous aeration of waste water and intermixing during the aeration phase as well as for a selective circulation – without air supply – during the mixing phase.

Recirculation of the waste water through the ejectors takes place automatically at the end of the aeration phase. Both phases can be alternated as often as required so that the independence of the waste water treatment process from feed conditions realised in the SBR process will be supported.

The ejectors, responsible for completely intermixing the tank contents during the mixing phase, are operated with the same circulation pumps used during the aeration phase. When the ejectors convey liquids, the power intake of the circulation pumps is utilised to an optimum – even during the mixing phase.

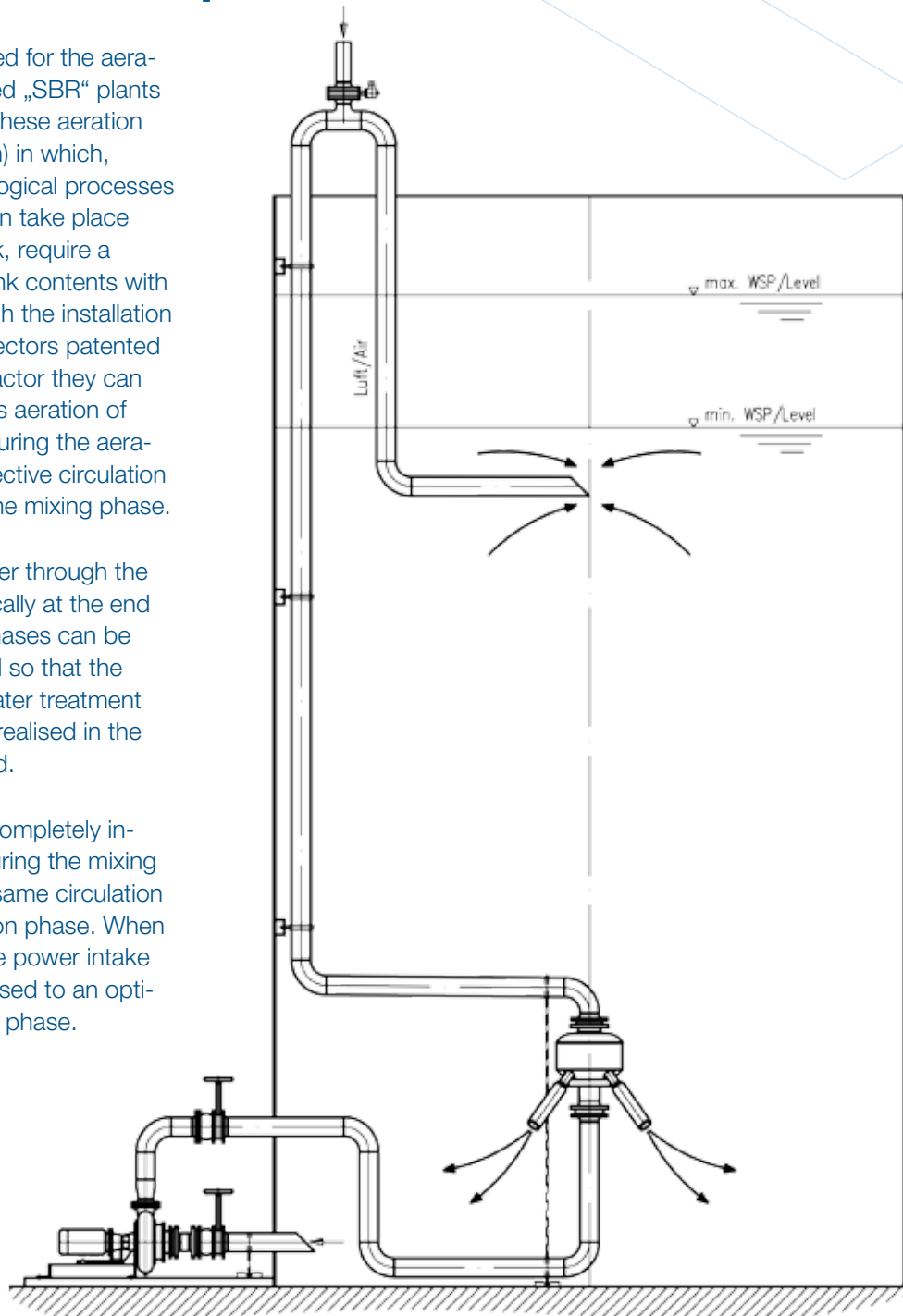

## Design acc. to requirements

The numerous layout and arrangement possibilities of ejectors and their differing operating methods with atmospheric air intake or compressed air provide ideal basic conditions for their application in large and small water treatment plants.



Ejectors and mixing nozzles for aeration and complete intermixing activities in a SBR reactor



# Water jet air compressors for introducing atmospheric air

Through individual adaptation of the flow channels (motive nozzle, mixing zone and diffuser) each water jet air compressor with atmospheric intake is customised for its application conditions (filling height, oxygen introduction). The maximum oxygen introduction at optimal energy efficiency is therefore always ensured.

Its installation can take place in the aeration tank as well as through the tank wall. The motive side of the water jet air compressor is connected to a circulation pump suited for the operation via a short pipeline. The suction side is carried above the filling height by means of a pipe or flexible hose pipeline.



3 water jet air compressors at the 4 000 m<sup>3</sup> clear filtrate storage tank of the paper mill "Blue Paper SAS" in Strasburg. Each water jet air compressor is operated by one circulation pump.



## Compact aerator

The so-called "compact aerator" is a combination of a water jet air compressor and a waste water submersible motor-driven pump mounted on a combined base frame. The effort required for installation of this compact unit is extremely low.

Compact aerators are utilised predominantly for

- cost-efficient retrofitting of aeration tanks
- installation in mixing and equalisation tanks
- during conversion or for peak load coverage in aeration tanks



Compact aerator/11 kW



# Ejectors for the introducing of gaseous oxygen

Ejectors for the introducing of gaseous oxygen are similar in construction form and mode of operation to apparatus supplied with compressed air.

They are installed principally within the aeration tank and are operated by dry- or wet-installed centrifugal pumps. The difference to the ejectors supplied with compressed air is that the gaseous oxygen is injected between the pressure side of the pump and the entrance to the ejector by a nozzle system in the connecting pipeline. So intermixing takes place at the highest pressure level, even before entry into the ejector.

The intermixing is intensified during perfusion of the ejector – whereby a considerable portion of the gas is dissolved already in the waste water. In the ejector, static pressure energy is converted into kinetic energy so that the two-phase mixture enters the aeration tank with high turbulence.

## Layout

Apart from multi-path ejectors, single-path jet ejectors find application as well. Installation can take place on the aeration tank floor as well as through the tank wall. All ejectors are manufactured in chrome-nickel steel whereby the material quality depends on the respective waste water composition. Furthermore, their compact construction form permits a later installation on a base frame as a mobile oxygen transfer system.

Six-path ejectors for intermittent pure oxygen gasing of refinery waste water in the Godorf works of Shell Deutschland Oil GmbH. Three each of the ejectors are combined by means of a pipeline and are fed collectively by a submersible motor-driven pump. This pump is connected to the pipeline by means of an underwater coupling device and can be retrieved via guide pipes at any time.







Mobile oxygen transfer system consisting of two ejectors and a submersible motor-driven pump mounted on a common base frame for application in the waste water treatment plant of a German gourmet food manufacturer. Installation took place by the Westfalen AG during plant production.

## Fields of application

Apart from oxygen introducing, ejectors can also be designed for the complete intermixing of an aeration tank – without gas supply – so that their utilisation facilitates an intermittent nitrification/de-nitrification – without additional agitators. The action of flow over the tank floor by the ejectors prevents deposits.

The oxygen transfer system is optimised by means of individual adaption of the maintenance-free ejectors to the respective operating conditions, power consumption and numbers of necessary pumps are reduced.

Ejectors are applied

- for peak load coverage
- for basic load coverage
- for introducing of gaseous oxygen occurring as off-gas in ozone plants

# Liquid jet gas compressors for introducing ozone

The introduction of ozone into liquids is an ideal field of application for liquid jet gas compressors. An ozone/air or ozone/oxygen mixture of approx. 10 % is taken from the ozone generator, vigorously intermixed with the flow requiring treatment and then transferred under high pressure to the downstream system. The distinguishing features of our transfer technology are an excellent mass transfer and the absolutely leak-proof compression of the toxic gas mixture in the liquid jet gas compressor.



Liquid jet gas compressor for ozone introduction in a municipal water treatment plant in Denmark

performance curves of a liquid jet gas compressor

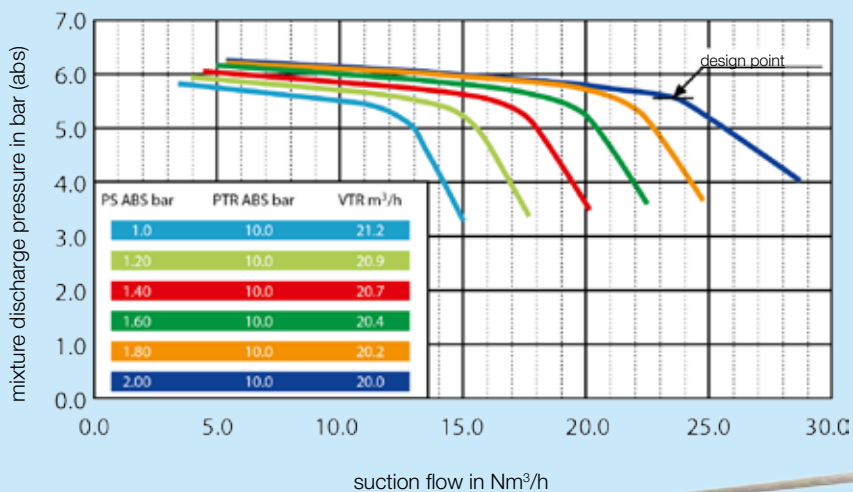

suction flow in Nm<sup>3</sup>/h



Liquid jet gas compressor for ozone treatment of drinking water at a water works in England



# Water jet air compressors for pressurised dissolved air flotation

Pressurised dissolved air flotation is a method of separating suspended solids. Microfine air bubbles adhering to the solid particles make them float to the surface where they can be removed. The air bubbles escape from the pressurised water being enriched with gas by lowering the pressure downstream of the relief valve.

To saturate the pressurised water a partial clarified water flow is utilised as motive flow for the water jet air compressor. Compressed air is supplied to its suction side. The mixture comprising of motive and suction flow is fed – below liquid level – into the saturation tank. A fine dispersion of air in the motive flow achieves an optimum air saturation degree of the pressurised water over the whole working range.

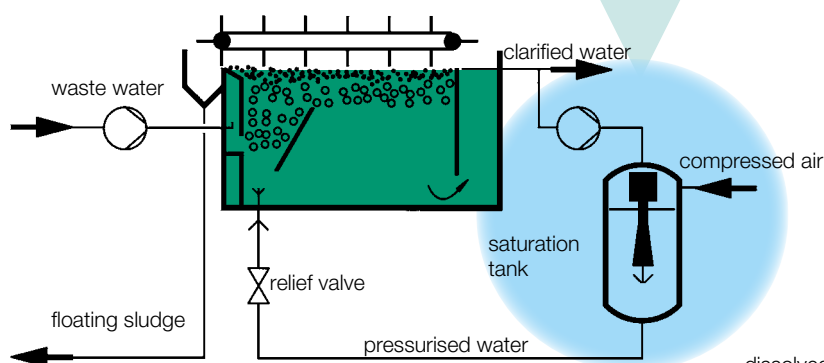
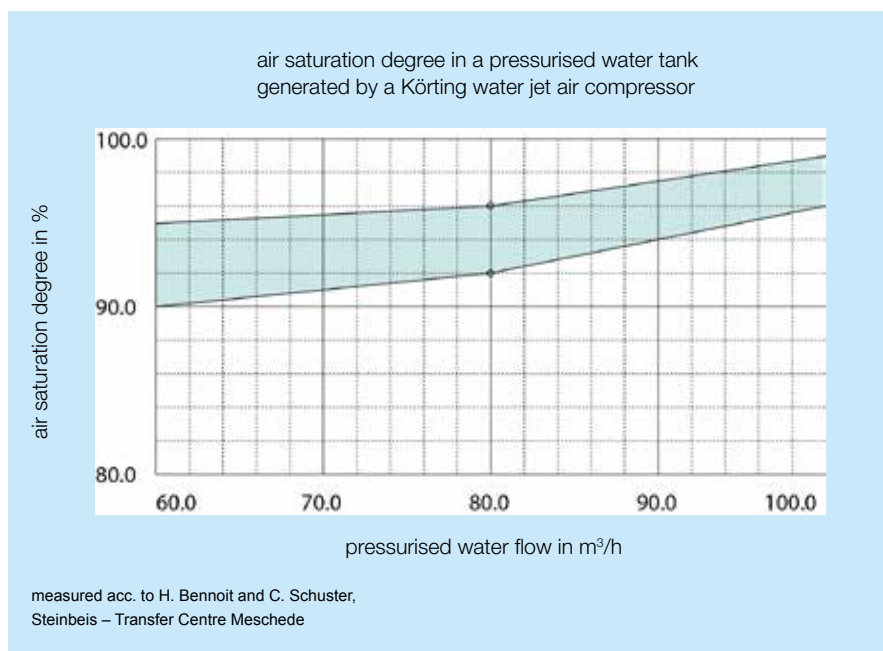

dissolved air flotation for secondary clarification in a biological water treatment plant

# Liquid jet mixing nozzles

Körting liquid jet mixing nozzles create special mixing systems which can be applied for continuous as well as discontinuous mixing duties. They can be used as a complete replacement for mechanical agitators and in many cases surpass their mixing results.

## Function

A liquid flow is taken from the tank and supplied to the liquid jet mixing nozzle via a centrifugal pump. Inside the motive nozzle pressure energy is converted to kinetic energy. Underpressure is generated at the motive nozzle outlet thereby sucking in liquid from the immediate vicinity. The suction flow is vigorously intermixed with the motive flow in the adjoining mixing passage and accelerated by impulse exchange. The drag effect of the exiting mixed flow strengthens the mixing effect.

Their essential advantages are:

- **low investment costs**
- **wear-resistant operation**  
no moving elements
- **no sealing problems**  
no through-going shaft in the waste water
- **no dead zones**  
the individual arrangement of liquid jet mixing nozzles permits installation in every tank geometry without influencing the mixing results



Flow conditions of a mixing nozzle designed by a computational fluid dynamics tool (CFD)



## Installation position and CFD simulation

The installation of the mixing nozzles shall take place in accordance with our instructions. A corresponding installation sketch or drawing is included with the scope of delivery. Installation proposals are available for nearly every tank geometry and which ensure a complete intermixing of the tank contents. To optimise the mixing effects and minimise energy input there is the additional possibility of a prior analysis of the installation situation and the performance data by means of computational fluid dynamics simulation (CFD). First of all, the geometrical contours of the tank as well as the mixing nozzles arranged therein are reproduced. Subsequently a calculation grid is generated and the spatial flow profile determined by means of the CFD is represented at different sectional planes.

The average flow velocity and the volume ratios of differing flow velocities are determined as calculative results. The CFD simulation permits a very good evaluation of the total system's mixing effect and leads, where appropriate, to considerable energy savings.

Optimisation of the flow conditions in a round tank through three dimensional computer simulation. Spatial distribution of the flow velocity as a coloured half-tone image.

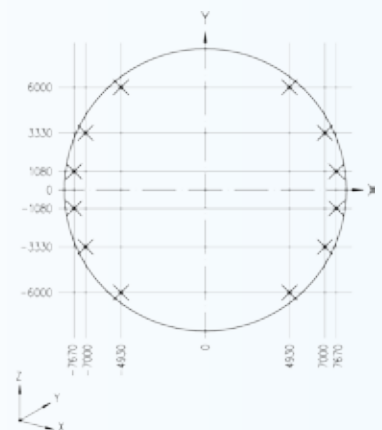
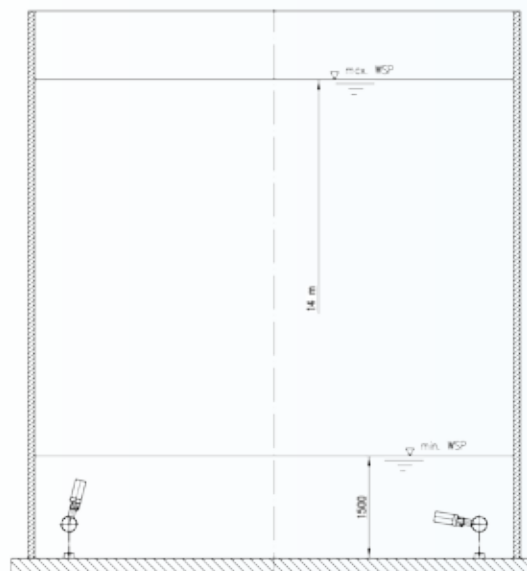
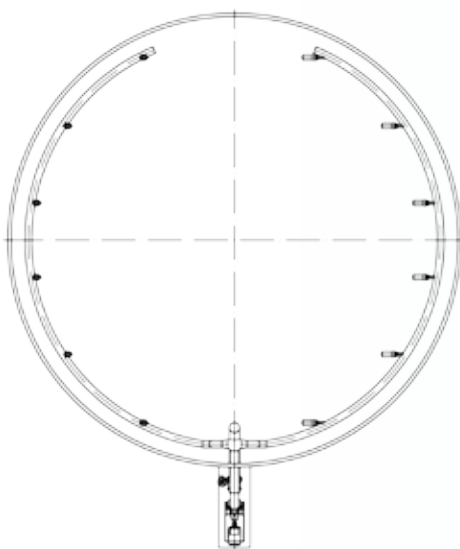
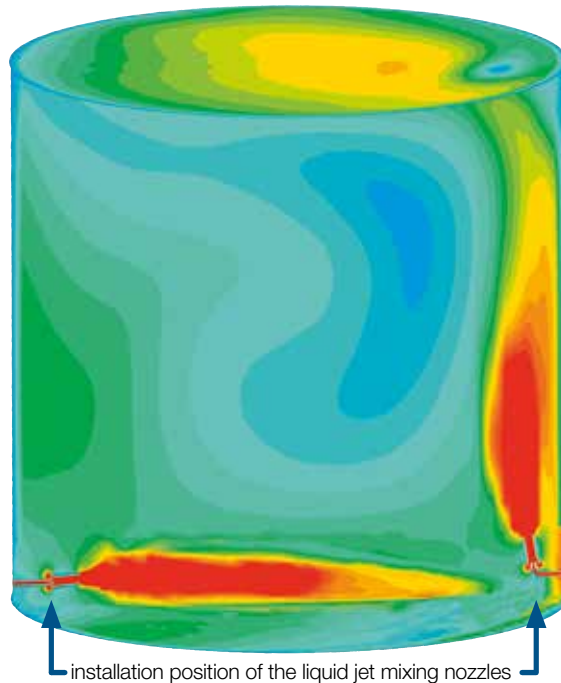

Liquid jet mixing nozzles for a 3 000 m<sup>3</sup> buffer tank in the paper industry



FED s.r.l.

Via dei Valtorta, 2  
20127 MILANO  
Italy

Tel.: +39 02 26826332

Fax: +39 02 26140150

E-mail: [fed@fed.it](mailto:fed@fed.it)

[www.fed.it](http://www.fed.it)